

REV	DESCRIPTION	DATE	APPROVED

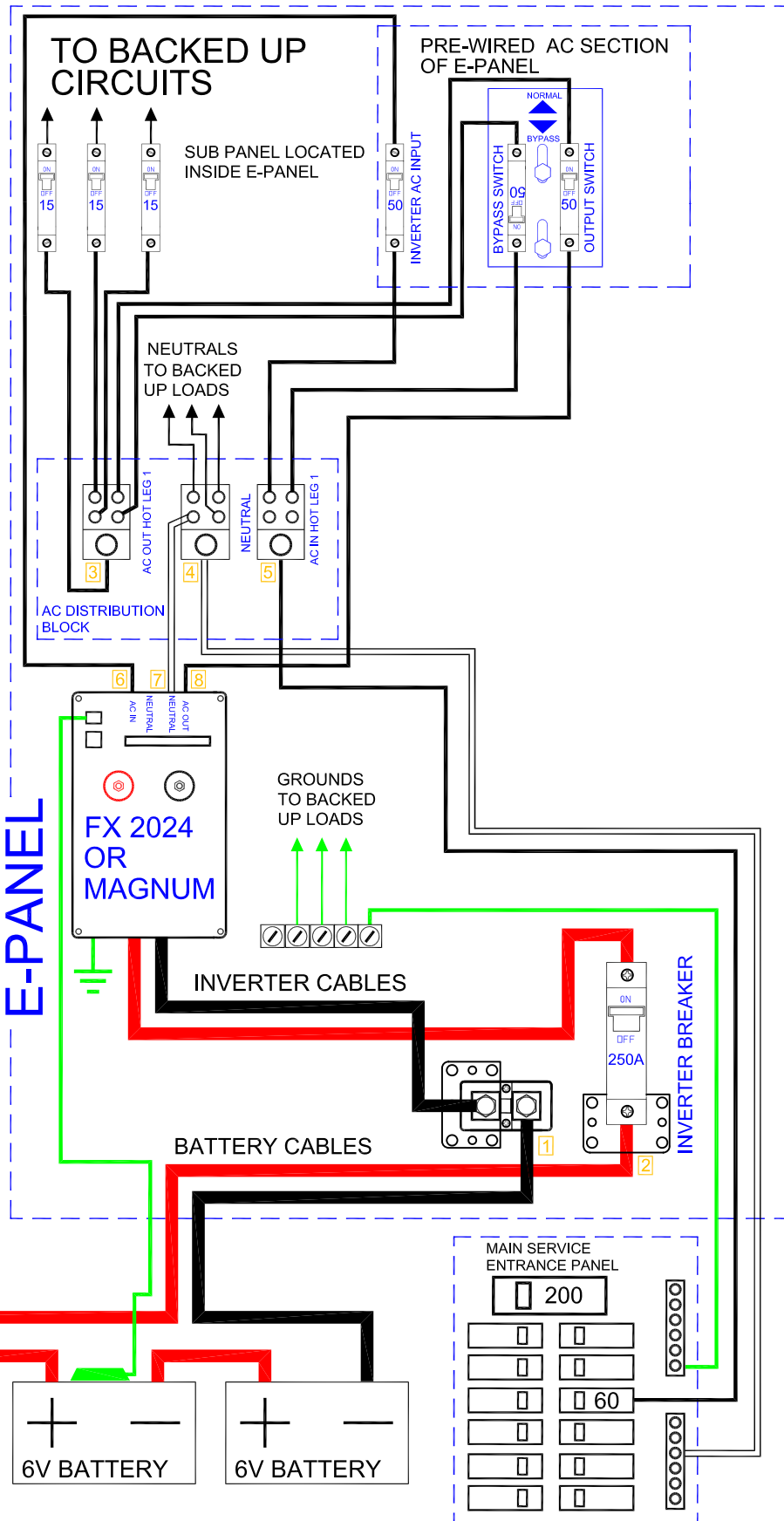

FIELD HOOK UPS (REQUIRED)

- 1 BATTERY BANK NEGATIVE
- 2 BATTERY BANK POSITIVE
- 3 AC HOT OUT TO DISTRIBUTION PANEL
- 4 NEUTRAL
- 5 AC HOT IN FROM UTILITY/GENERATOR
- 6 AC HOT IN WIRE TO INVERTER
- 7 AC NEUTRAL WIRE TO INVERTER
- 8 AC HOT OUT WIRE TO INVERTER

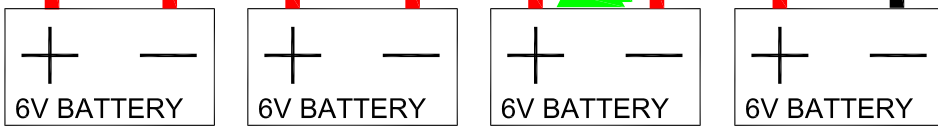

14000 BURN RD
ARLINGTON, WA
98223 USA

E-PANEL-BACKUP-POWER