



MNPV4BY3 MANUAL

12-String, 3-Output PV Combiner

MNPV4BY3



This entire manual is printed without color but is available for download—with many of the diagrams available in color—on our website at midnitesolar.com.



MNPV4BY3 MANUAL

INTRODUCTION

The **MNPV4BY3** is a 1000VDC photovoltaic (PV) combiner utilizing touch-safe fuseholders, offering three separate PV outputs for off-grid and grid-tie applications. Up to four PV strings are combined per PV output.

Features:

- SGS Listed to UL Standards for USA and Canada
- Three independent, 4-string combining
- Three independent PV negative busbars
- Chassis ground busbar, up to #1/0 AWG
- Aluminum powder-coated enclosure
- Plastic deadfront protects all wiring
- Mounts vertical (or to 10-degrees)
- 120A per busbar, tin-plated copper
 - MAX fuse rating is 30A
 - Fuseholder terminal rating is 30A
- Three outputs ... #6 - #2/0 AWG
- Twelve inputs ... #14 - #6 AWG
- Fuseholders and fuses included
- DIN rail mounted fuseholders
- NEMA 3R rated enclosure
- Twelve strain reliefs
- Conduit Knockouts:
 - Twelve 1/2" on bottom panel
 - Two 2" on side and bottom panels

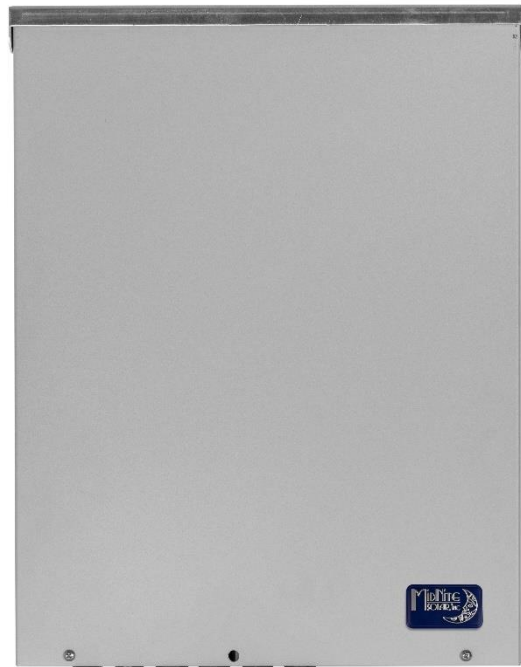



MNPV4BY3 MANUAL

IMPORTANT SAFETY INSTRUCTIONS SAVE THESE INSTRUCTIONS

THIS MANUAL CONTAINS IMPORTANT SAFETY INSTRUCTIONS FOR THE MIDNITE SOLAR MNPV4BY3 PHOTOVOLTAIC COMBINER THAT SHALL BE FOLLOWED DURING INSTALLATION AND OPERATION.

If you do not fully understand any of the concepts, terminology, or hazards outlined in these instructions, please refer installation to a qualified dealer, electrician, or installer. These instructions are not meant to be a complete explanation of a renewable energy system. Before using the PV combiner, read all instructions and cautionary markings. The installation instructions are for use by qualified personnel only. Do not perform any installation other than that specified in this manual unless you are qualified to do so. Incorrect installation may result in a risk of electric shock, fire, or other safety hazard.

Safety Symbols

The following safety symbols have been placed throughout this manual to indicate dangerous and important safety instructions.

WARNING!

WARNING indicates a hazardous situation which, if not avoided, could result in death or serious injury.

CAUTION!

CAUTION indicates conditions or practices that could result in damage to the unit or other equipment.

INFO: Indicates information that emphasizes or supplements important points of the main text.

STANDARDS

The MidNite Solar **MNPV4BY3 Photovoltaic Combiner** conforms to *UL 1741, Safety for Inverters, Converters, Controllers and Interconnection System Equipment for Use with Distributed Energy Resources, UL 1741:2010 Ed.2+R:15Feb2018; CSA C22.2#107.1:2016 Ed.4.*



MNPV4BY3 MANUAL

SAFETY PRECAUTIONS

- The **MNPV4BY3 PV Combiner** is listed as a Type 3 enclosure, designed for outdoor installation. Mount the PV Combiner vertically or up to a 10-degree angle.
- System grounding is the responsibility of the system installer and must comply with local and national electrical codes and standards.
- Listed or labeled equipment shall be installed and used in accordance with any instructions included in the listing or labeling.
- All electrical work must be performed in accordance with local and national electrical codes.
- Use only #12 AWG (or larger) copper wires with a minimum temperature rating of 90°C.
- Use insulated tools to reduce the chance of electrical shock or accidental short circuits.
- Install using Class 1 wiring methods. There are no Class 2 circuits in this PV Combiner.
- Only qualified service personnel can remove front cover, shock hazards are present.
- Torque all wiring and cable connections to the required torque values.
- All unused conduit holes must be filled with a UL listed conduit plug.
- Activate the system DC disconnect before opening the fuseholders!
- The PV Combiner must be properly grounded.

WARNING!

High voltage is present in this PV combiner and can cause severe injury or death. Wear Personal Protective Equipment before opening or performing diagnostic measurements while energized.

BATTERY SAFETY

- Wear eye protection and avoid touching your eyes and face when working with batteries to keep any fluid/corrosion on the battery from contact with eyes and skin. Have plenty of fresh water and soap nearby and thoroughly wash in case battery acid contacts skin, clothing, or eyes. In the event of exposure to the eyes, flood them for at least 15 minutes with running water and seek immediate medical attention. Baking soda neutralizes lead acid battery electrolyte and vinegar neutralizes spilled NiCad and NiFe battery electrolyte; depending on your battery type, keep a supply on hand near the batteries.
- Follow the battery manufacturer's safety precautions before installing an inverter and batteries. Always verify proper polarity and voltage before connecting batteries to the inverter. Once the batteries are connected to the inverter, ensure the maintenance and charging requirements (i.e., charge voltage and charge rate) provided by the battery



MNPV4BY3 MANUAL

manufacturer are followed to extend the life of the batteries and to prevent damage to the batteries while charging.

- The battery bank should be installed in a clean, dry, ventilated environment protected from high and low temperatures. If installed in a vehicle/boat, the batteries must be mounted upright (if using liquid batteries) and securely fastened. The location must be accessible and protected from exposure to heat producing devices, and away from any fuel tanks.
- Batteries can produce explosive gasses, so install batteries in a well-ventilated area. For compartment or enclosure installations, always vent batteries from the highest point to the outside. Design the battery enclosure to prevent accumulation and concentration of hydrogen gas in pockets at the top of the compartment.
- Remove all jewelry such as rings, watches, bracelets, etc., when installing or performing maintenance on the batteries and inverter. A battery can produce a short-circuit current high enough to weld metal jewelry, causing severe burns.
- Use insulated tools and be very careful when working around batteries, they can produce extremely high currents if short-circuited (e.g., dropping a metal tool across the battery terminal), which could cause a fire or explosion.
- When replacing some of the batteries in a bank, always replace with the **same** model, size, Ah capacity, charging voltages, and type of the old batteries. Types include: (Flooded, Lithium, NiFe, sealed, etc.).
- To prevent a spark at the battery and to reduce the chance of explosion, always connect the cables to the batteries first. Then connect the cables to the inverter.
- Never work alone. Always have someone within the range of your voice or close enough to come to your aid when working around batteries.
- Never use old or untested batteries. Check each battery's label for age, type, and date code to ensure all batteries are identical.
- Proper disposal of batteries is required. Refer to your local codes for disposal requirements.
- Batteries are sensitive to changes in temperature. Install batteries in a stable environment.
- Provide at least one inch of air space between batteries to provide optimum cooling.
- For batteries that require the addition of water, follow these important safety tips:
 - Electrolyte Level – **NO** exposed plates! Ensure plates are covered in electrolyte and slightly below the bottom "funnel" of the battery fill hole.
 - Add distilled water as needed. Do **NOT** fill to the bottom of the funnel neck before you equalize. The electrolyte will probably spill out.
 - Use the MidNite Solar's MNHYDROMETER to measure the specific gravity. Check with your battery manufacturer for the specific gravity values.
- Use proper lifting techniques when working with batteries.
- Never smoke or allow a spark near batteries.
- Never charge a frozen battery.



MNPV4BY3 MANUAL

HOW TO **KILL** YOUR BATTERIES

Batteries are delicate and require proper attention, especially when off-grid. Think of your batteries and solar equipment as a small nuclear power plant, hydro dam, or natural gas-fired power plant. Just like any of those, your system needs DAILY attention to ensure it is performing correctly and safely. We recommend the use of an independent battery monitor/alarm if you have an expensive battery bank. Below is a list of some of the most common ways we have seen people kill their battery bank.

- Using more than three parallel strings and not using common bus bars. With lead-acid batteries, when you use more than three strings, it is very hard to properly charge the middle strings. The only safe way to do this is to wire each string with equal length cables to a common bus bar. Connect inverter cables to the farthest points on the busbars.
- Not watching to verify the Absorb or EQ times are set properly, and that the equipment actually charges for that period of time. Some equipment will have settings like “End Amps” that can terminate Absorb early and, if set up wrong, can damage a battery.
- Not using ALL EQUAL LENGTH interconnect cables on each string. It is important that ALL strings be wired EXACTLY the same. Any variance in resistance on one string versus another will cause an imbalance and the batteries will suffer a shortened lifespan.
- Trusting a State of Charge (SOC) meter, which can lose calibration over time and give you false readings. You need to verify specific gravity and or verify the charge voltage is being met. Never fully rely on the SOC %; it is just a good, quick reference.
- Routinely using more than 50% of the capacity of the lead acid battery. Using more than half the battery capacity drastically shortens the batteries life; occasionally is fine, but daily will kill lead acid batteries in months.
- Not leaving ample space between cells for cooling. We recommend at least one inch between the cells for cooling. Ask the battery manufacturer what they recommend.
- Not having enough charge current to properly charge the size of the battery you have. Consult the battery manufacturer for the minimum charge current.
- Using tap water or other liquids instead of distilled water in a flooded battery. The minerals in the tap water will destroy a battery.
- Not verifying the temperature compensation neutral point (typically 25°C) and the milli volts per degree C per cell (typically -5mV).
- Not verifying you are charging to the voltage supplied by the battery manufacturer.
- Not fully charging your lead acid batteries at least once a week.
- Failing to keep all connections clean.

WIRING REQUIREMENTS

- The NEC (*National Electric Code, ANSI/NFPA 70*) for the United States and the CEC (*Canadian*



MNPV4BY3 MANUAL

Electrical Code, Part 1) for Canada provide standards for safely wiring residential and commercial installations. The NEC and CEC list the requirements for wire size, over-current protection, and installation methods.

- Wires to and from solar equipment must be protected as required by code. This can be done by using jacketed wires or by feeding the wires through conduit or a conduit box.
- Always check for existing electrical, plumbing, or other areas of potential damage prior to making cuts in structural surfaces or walls.
- Wiring should meet all local codes and standards and be performed by qualified personnel such as a licensed electrician.
- Use only #12 AWG (or larger) copper wires with a minimum temperature rating of 90°C.
- Over-current protection must be provided as part of any installation.
 - Coordination of conductor sizes and over-current protection shall be done in accordance with the NEC and the CEC, Part 1.
 - **NOTE** – Breakers/fuses protect the wire, not the equipment.
- The equipment ground is marked with this symbol: 

WARNING!

Ensure all sources of DC power (batteries) and AC power (utility or AC generator) are de-energized (breakers opened, fuses removed) before proceeding—to prevent accidental shock.

INSTALLING THE MNPV4BY3

PV Combiners are normally installed at the PV array to reduce the number of PV wires to only the primary PV+/PV- inputs. The PV Combiner can be mounted in the vertical position or slanted backwards up to 10 degrees to accommodate a 3/12 roof pitch.



Various PV Combiner Installations



MNPV4BY3 MANUAL

If installed inside the dwelling by the solar equipment, then the National Electrical Code (NEC) requires 30" clear on the wall. The **MNPV4BY3** may be located anywhere within this 30". The NEC also requires 36" free and clear of obstructions in front of the combiner. The 36" clear area in front of electrical panels is to provide a space to fall back into in case of electrical shock.

All unused holes should be blocked using RTV sealant or duct seal in order to keep rain and bugs out of the enclosure. It is common for critters to enter through an unused mounting hole, which may eventually degrade the performance of your system.

Mounting

- Determine suitable installation location.
- PV Combiner has pre-drilled holes on back panel for mounting.
- Use appropriate mounting hardware and ensure the PV Combiner is securely fastened.
- Mount PV Combiner vertically (up to 10 degrees); the top panel is water-tight.

Conduit Knockouts

- Knockouts are concentric plugs, that once removed reveal holes in the enclosure for wire passage. The holes can accept MC cable connectors, strain reliefs, or conduit fittings. Several brands will fit the ½" diameter knockouts.
- The knockout is nominally held in place with a small dot of metal called "point of attachment." Position screwdriver opposite the point of attachment, gently strike screwdriver handle with hammer. Twist knockout off with fingers or pliers.



WIRING THE MNPV4BY3

Insert PV Array Wires (Figure 1)

- Notice on **Figure 1** there are 3 groups of fuseholders (**#1**), labeled **A**, **B**, and **C**. Notice there are 3 groups of PV- busbars (**#2**), also labeled **A**, **B**, and **C**. The PV wires from one array need to be grouped accordingly ... PV+ wires to **A**, PV- wires to **A**; same for group **B** and group **C**.
 - This is important for voltage testing and inverter operation.
- Insert PV+ wires from PV array #1 into bottom terminals of the "A" fuseholders (**#3**).
- Torque to 29.4 in-lbs.
- Insert PV- wires from PV array #1 into the "A" PV- busbar (**#2**).
- Torque (See page 10, **Figure 2, #1**).
- Repeat for PV array #2 to "B" and PV array #3 to "C."

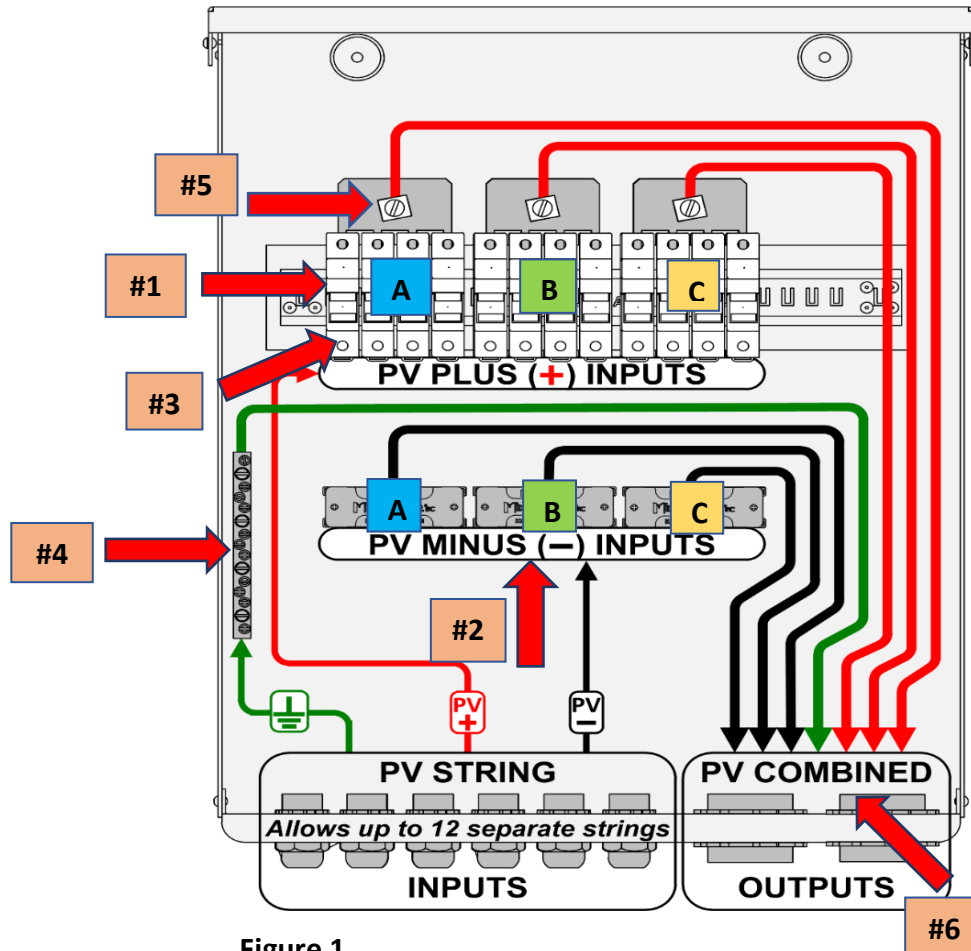

Figure 1

Insert Ground Wires (Figure 1)

- PV module frames must be grounded. Bond the modules together with bonding straps or use module mounting hardware that pierces the frames.
- Insert PV array ground wire into PV Combiner ground busbar, (#4).
- Insert Grounding Electrode Conductor into ground busbar (#4) and at Grounding Electrode.
- Torque ground busbar setscrews (See page 10, Figure 2, #2).

Insert PV “Homerun” Wires (Figure 1)

- Insert PV+ “homerun” wire (#6) for Inverter #1 (fuseholder group “A”) into box lug on the PV+ busbar (#5).
- Torque (See page 10, Figure 2, #1 for Large Setscrews).
- Insert PV- “homerun” wire (#6) for Inverter #1 into the PV- busbar (“A”) (#2).
- Torque (See page 10, Figure 2, #1).
- Repeat for Inverter #2 with group “B” and for Inverter #3 with group “C.”



MNPV4BY3 MANUAL

TESTING THE MNPV4BY3

Check PV Voc – Fuseholder OPEN

- With fuseholder fuse trays open, measure for PV Voc between the fuseholder bottom terminal setscrew and the corresponding PV- busbar.
- Check each PV string, at each fuseholder, for proper PV Voc.



Fuseholder opened under load!!

Check PV Voc – Fuseholder CLOSED

- Open the PV DC disconnect or turn inverter OFF.
- Close one fuseholder at a time.
- Check for proper PV Voc between corresponding PV+ and PV- busbars.
- Open that fuseholder tray. Close next fuseholder tray, check for proper PV Voc.
- Check one fuseholder at a time to ensure each fuse is good.
- After each fuse checks good, close all trays.
- Check for proper PV Voc at each inverter PV input.
- If all voltages check good, the inverter may be energized.

WARNING!

Touch safe fuse holders should never be opened under load! This is not one of those warnings to gloss over! If opened under load, you **WILL** have a fire and it will not stop until the wires burn in half.

CAUTION!

MNPV4BY3 MAX FUSE RATING – 30A

CAUTION!

Use 1000VDC multimeter or damage may occur.

Important! Re-torque all connections after one hour. Do **NOT** skip this step. You may be surprised by how much the connections may loosen after the initial tightening.

#1

TORQUE SMALL BUS SCREWS 18-10 AWG 20 IN LBS.
 TORQUE SMALL BUS SCREWS 8 AWG 25 IN LBS.
 TORQUE SMALL BUS SCREWS 6 AWG 35 IN LBS.
 TORQUE LARGE BUS SCREWS 18-10 AWG 35 IN LBS.
 TORQUE LARGE BUS SCREWS 8 AWG 40 IN LBS.
 TORQUE LARGE BUS SCREWS 6-4 AWG 45 IN LBS.
 TORQUE LARGE BUS SCREWS 3-1/0 AWG 50 IN LBS.

GROUND

TORQUE SMALL SCREWS TO 20 IN-LBS (2.3NM)
 TORQUE LARGE SCREWS TO 45 IN-LBS (5.1 NM)

Figure 2

#2

Check Live Circuit Before Removing PV Combiner Deadfront (Figure 3)

The **MNPV4BY3** deadfront offers test points to check for active voltages **BEFORE** removing the deadfront for servicing inside the PV Combiner.

- Open PV DC disconnect or turn OFF inverter.
- Open each fuseholder tray.
- Measure between test points **PV1+** (Figure 3, #1) and **PV1-** (Figure 3, #2) for voltage.
- Repeat for test points **PV2+/PV2-** and **PV3+/PV3-**.
- If no voltage is present at all 3 test points, then you may remove the deadfront cover.

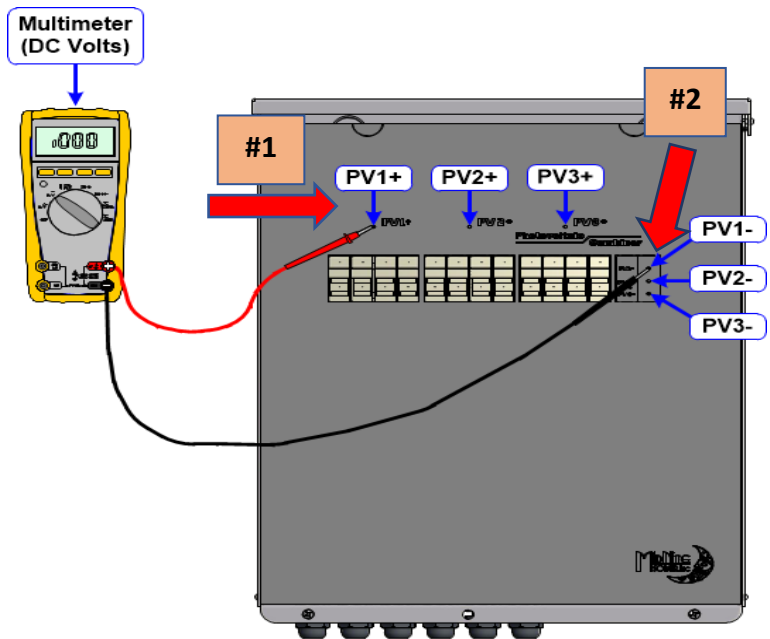

Figure 3

FUSEHOLDER SPECIFICATIONS

- Rated: 1000VDC, 30A / 1100VDC, 32A
- Rated Breaking Capacity: 30kA at 1000VDC / 20kA at 1100VDC
- Wire Range: 18-8 AWG (1.5-10 mm²)
- Max. Torque: 3.4 Nm
- Maximum Heat Dissipation: 6W
- Operation Temperature: -40 °C to 130 °C
- Material Flammability: UL 94 V0
- Degree of protection: IP20
- Mounting: DIN Rail mounting
- Standards: UL 4248-19; EN 60947-3
- Approvals: UL (File: E486822); TUV (File: R50393963)
- Standard 10x38 mm cylindrical PV fuses.
- Use #12 AWG (or larger) copper wire rated at 90C.



MNPV4BY3 MANUAL

NOTE

The MNPV4BY3 PV Combiner is to be connected to a 1000VDC PV array and (up to 3) 50,000W Solar Edge inverters.

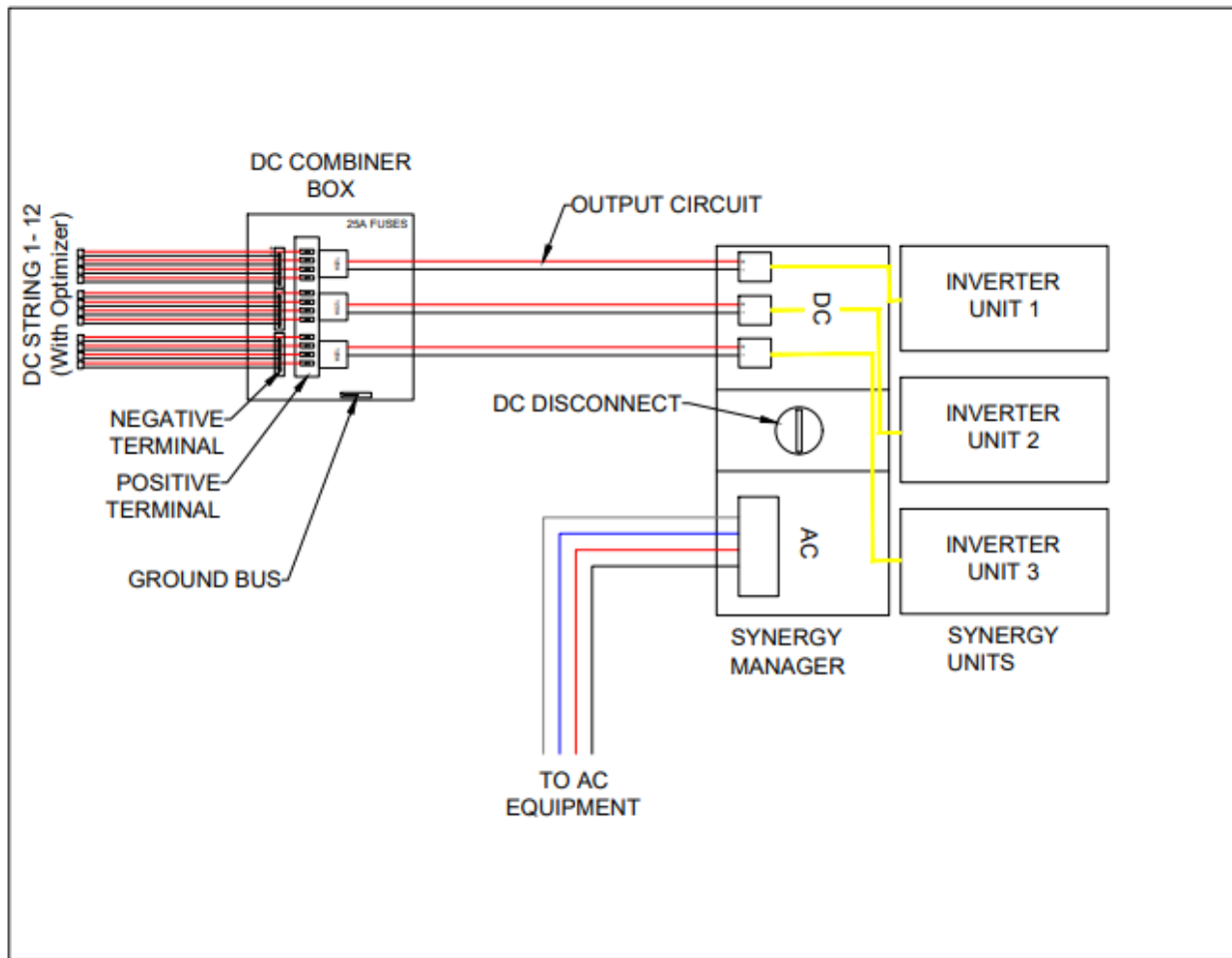



MNPV4BY3 MANUAL

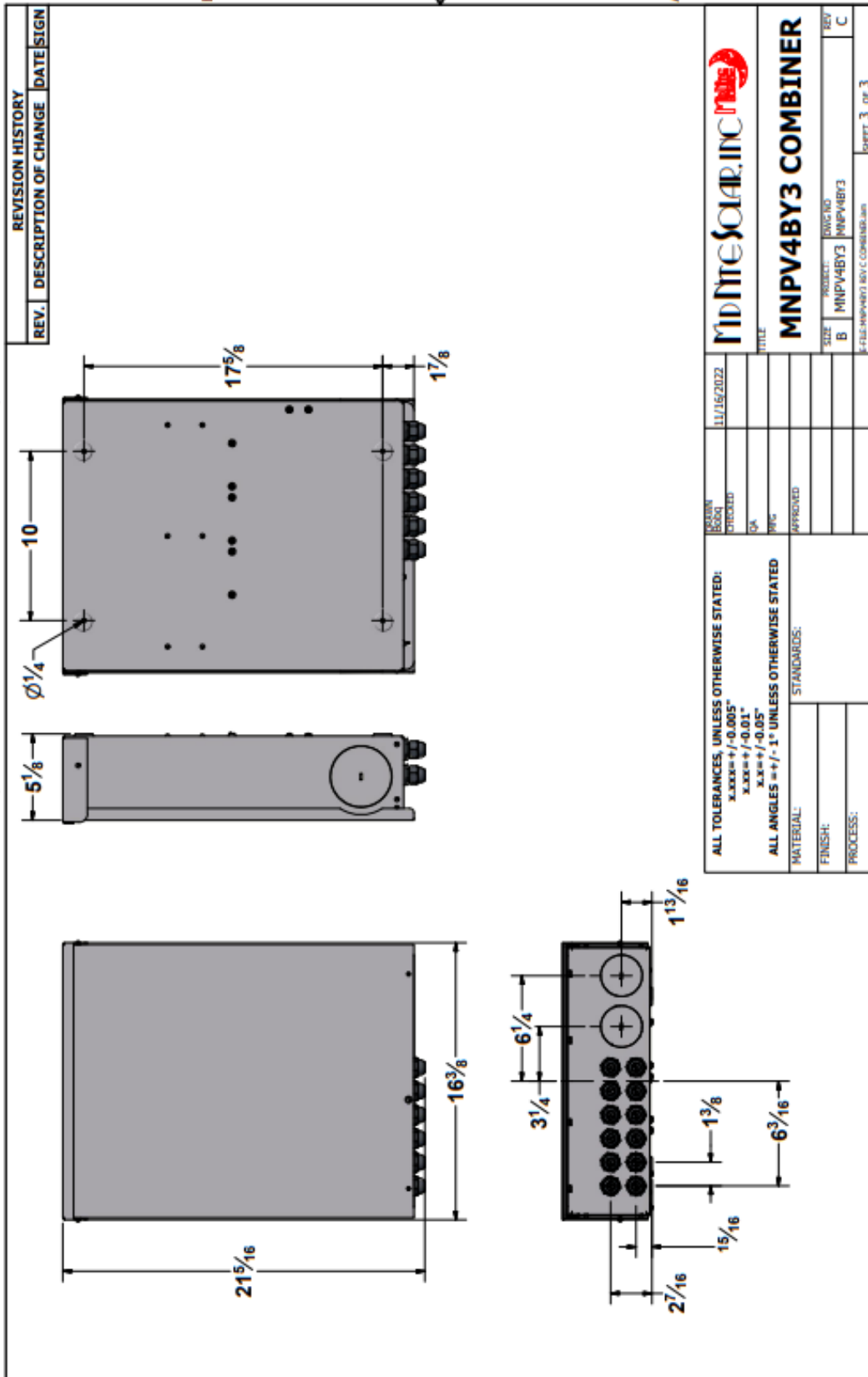



MNPV4BY3 MANUAL

MIDNITE SOLAR INC. LIMITED WARRANTY

MidNite Solar Power electronics, sheet metal enclosures and accessories

MidNite Solar Inc. warrants to the original customer that the MNPV4BY3 shall be free from defects in materials and workmanship. This warranty will be valid for a period of five (5) years.

MidNite Solar will not warranty third party inverter components used in MidNite's pre-wired systems. Those components are warranted by the original manufacturer.

At its option, MidNite Solar will repair or replace at no charge any MidNite product that proves to be defective within such warranty period. This warranty shall not apply if the MidNite Solar product has been damaged by unreasonable use, accident, negligence, service, or modification by anyone other than MidNite Solar, or by any other causes unrelated to materials and workmanship. The original consumer purchaser must retain original purchase receipt for proof of purchase as a condition precedent to warranty coverage. To receive in-warranty service, the defective product must be received no later than two (2) weeks after the end of the warranty period. The product must be accompanied by proof of purchase and Return Material Authorization (RMA) number issued by MidNite Solar. For an RMA number contact MidNite Solar Inc., (360) 403-7207. Purchasers must prepay all delivery costs or shipping charges to return any defective MidNite Solar product under this warranty policy. Except for the warranty that the products are made in accordance with, the specifications therefore supplied or agreed to by customer:

MIDNITE SOLAR MAKES NO WARRANTY EXPRESSED OR IMPLIED, AND ANY IMPLIED WARRANTY OF MERCHANTABILITY OR FITNESS FOR A PARTICULAR PURPOSE WHICH EXCEEDS THE FOREGOING WARRANTY IS HEREBY DISCLAIMED BY MIDNITE SOLAR AND EXCLUDED FROM ANY AGREEMENT MADE BY ACCEPTANCE OF ANY ORDER PURSUANT TO THIS QUOTATION. MIDNITE SOLAR WILL NOT BE LIABLE FOR ANY CONSEQUENTIAL DAMAGES, LOSS OR EXPENSE ARISING IN CONNECTION WITH THE USE OF OR THE INABILITY TO USE ITS GOODS FOR ANY PURPOSE WHATSOEVER. MIDNITE SOLAR'S MAXIMUM LIABILITY SHALL NOT IN ANY CASE EXCEED THE CONTRACT PRICE FOR THE GOODS CLAIMED TO BE DEFECTIVE OR UNSUITABLE.

Products will be considered accepted by customer unless written notice to the contrary is given to MidNite Solar within ten (10) days of such delivery to customer. MIDNITE SOLAR is not responsible for loss or damage to products owned by customer and located on MIDNITE SOLAR'S premises caused by fire or other casualties beyond MIDNITE SOLAR'S control. This warranty is in lieu of all other warranties expressed or implied.

MIDNITE SOLAR INC.



MNPV4BY3 MANUAL

NOTICE OF COPYRIGHT

MidNite Solar's **MNPV4BY3 PV Combiner** User's Manual.

Copyright © 2024 All rights reserved.

MidNite Solar, Inc. reserves the right to revise this document and to periodically make changes to the content hereof without obligation or organization of such revisions or changes unless required to do so by prior arrangement.

DISCLAIMER

Unless specifically agreed to in writing, MidNite Solar Inc.: (a) Makes no warranty as to the accuracy, sufficiency, or suitability of any technical or other information provided in its manuals or other documentation; (b) Assumes no responsibility or liability for loss or damage whether direct, indirect, consequential, or incidental, which might arise out of use of such information. The use of any such information will be entirely at the user's risk.

CONTACT

360.403.7207

customerservice@midnitesolar.com

www.midnitesolar.com

