

DUAL SUNNY ISLAND WITH 3 CLASSICS

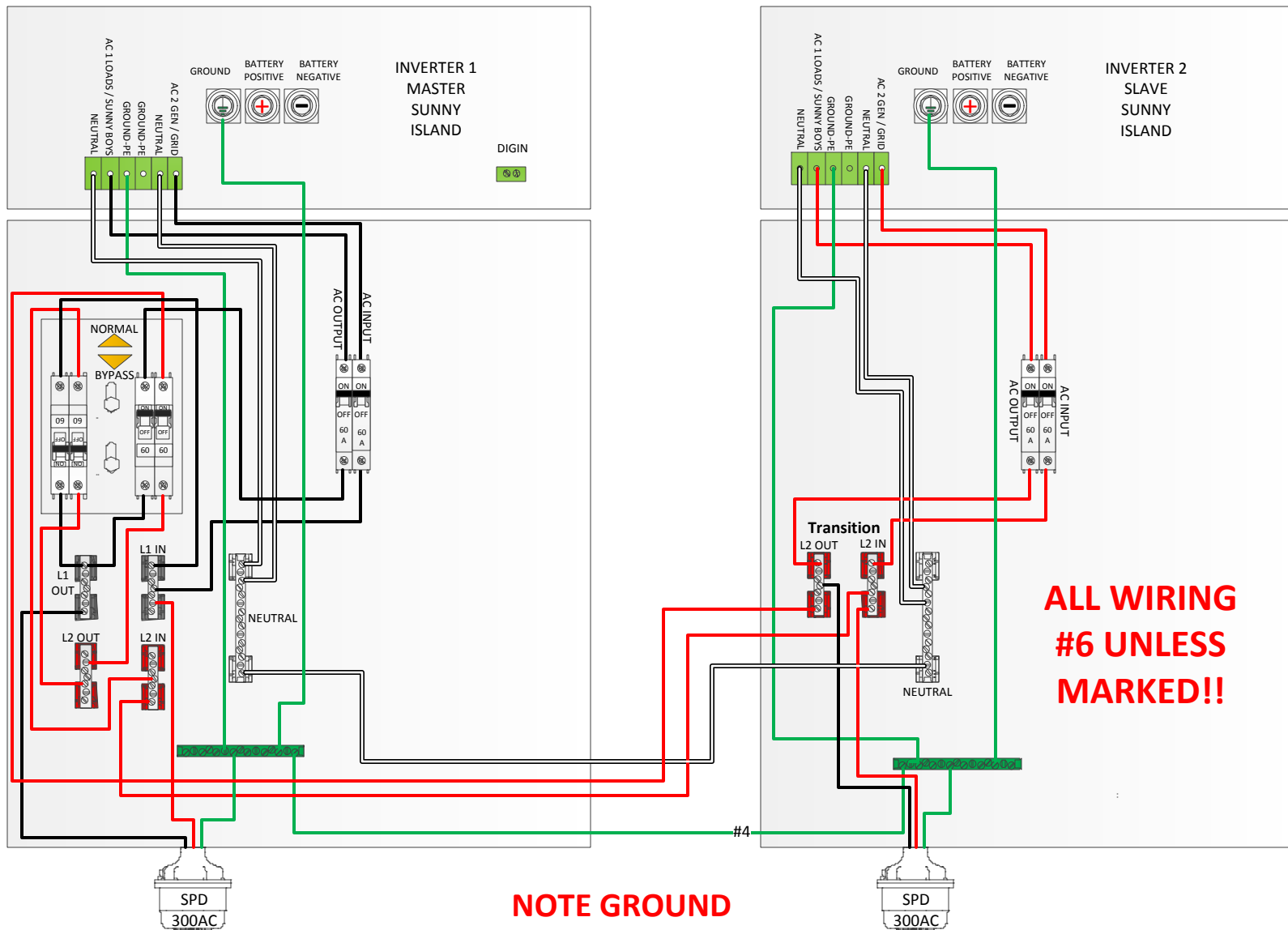

**ALL WIRING
#6 UNLESS
MARKED!!**

**NOTE GROUND
INTERCONNECT IS #4**

DC AND COMMUNICATION CABLES FACTORY INSTALLED BY MIDNITE SOLAR

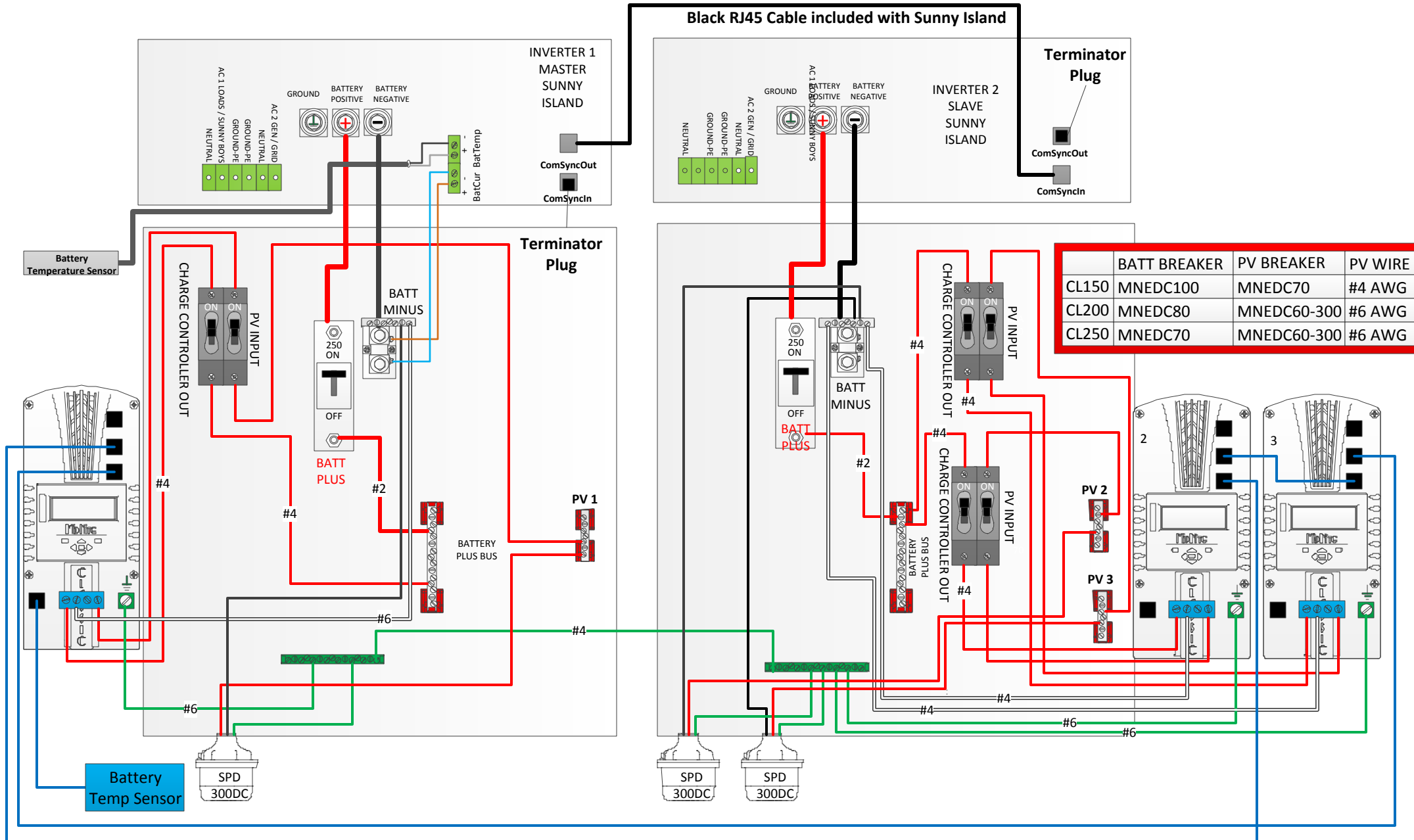

AC WIRING TO BE DONE BY CUSTOMER

System must be grounded per NEC specifications

