

Version: V1.0

MN 15-12KW-AIO

All in one Inverter/Charger System



QUICK INSTALLATION GUIDE

1. Packing List

The box should include all items shown in the component guide. If there is damage or missing parts, immediately call the phone number (USA) (360)-403-7207.

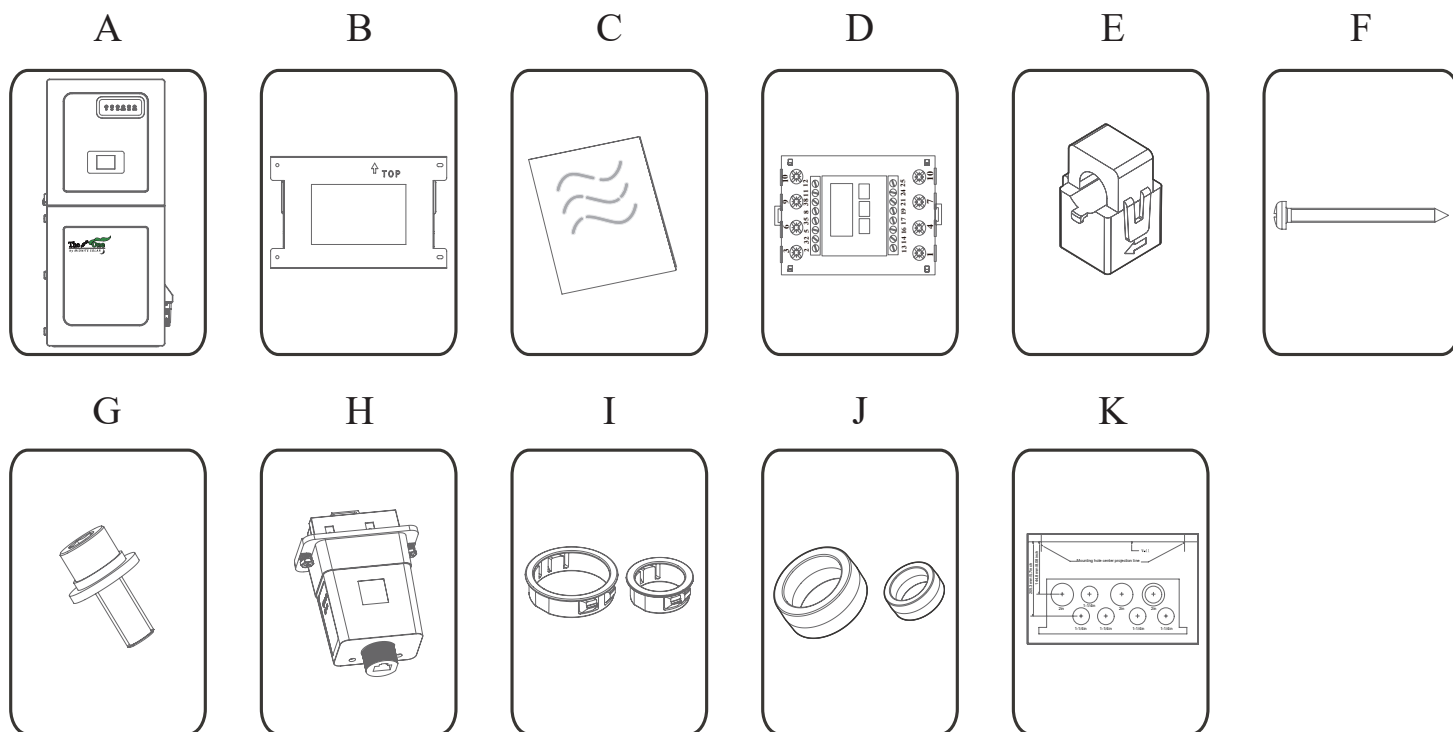

Component	Description	Quantity
A	Inverter	1
B	Mounting Bracket	1
C	File Package	1
D	Meter (Optional)	1
E	CT	2
F	M6 Self-tapping Screw	4
G	M6 Security Screw	1
H	WiFi/Ethernet Dangle	1
I	Bushing Ring (φ67.5mm & φ49mm)	φ67.5mm: 3 φ49mm: 6
J	Toroid (φ53mm(Battery) & φ30mm(Ground of Grid))	2
K	Gutter Template	1

1.1 General Description

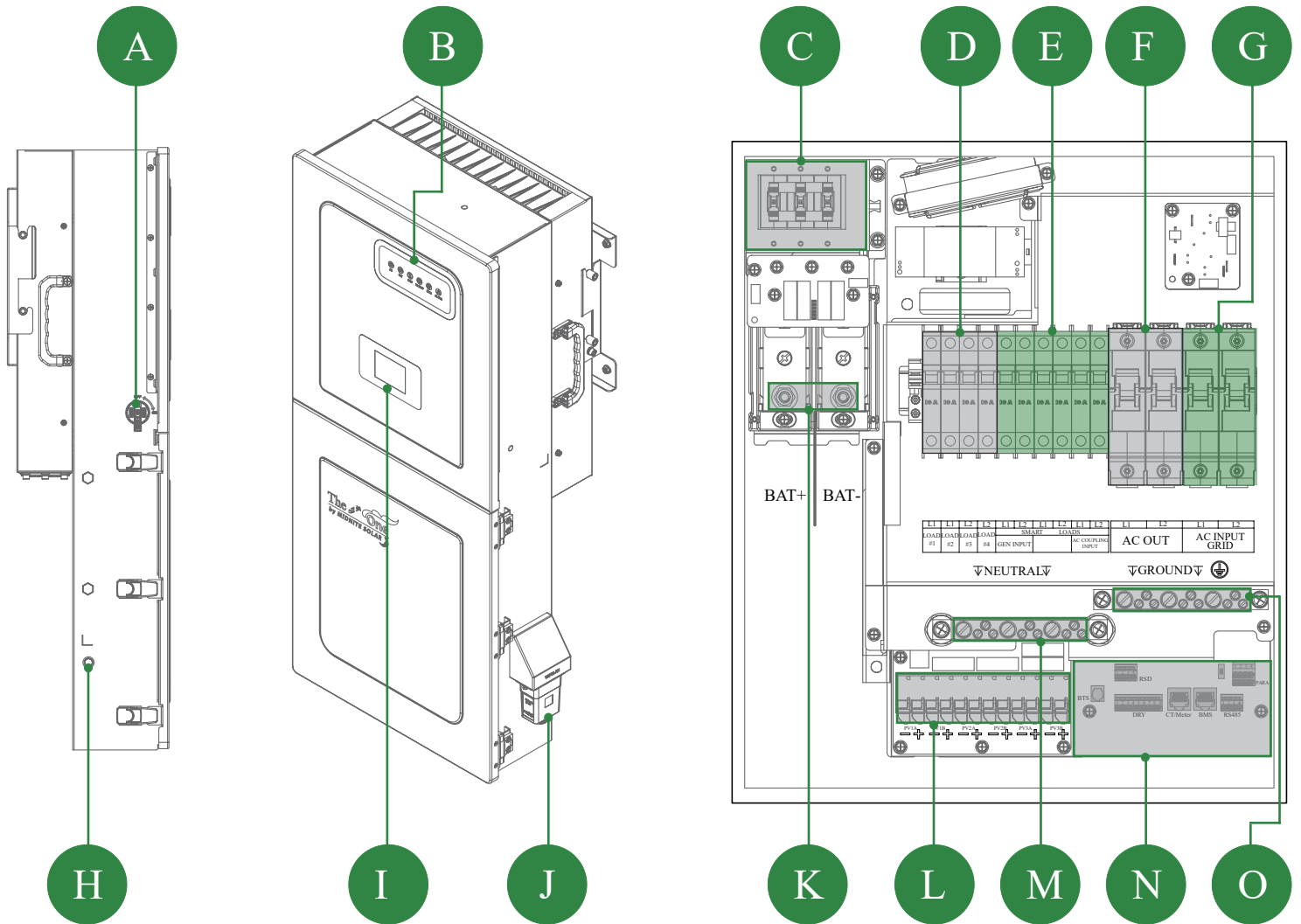

Component	Description
A	PV switch
B	LED screen
C	300 amp Hydraulic/magnetic Bat breaker
D	Three 15A & one 20A 120VAC Load brkrs
E	120/240VAC Smart load brkrs 60+30+50A OR 60A Gen input+ 30A Smart Load+50A AC coupling --Use each dual breaker as a load or input and program accordingly
F	100A 120/240VAC AC OUT
G	100A 120/240VAC AC IN
H	ON/OFF Button
I	LCD screen

Component	Description
J	Wi-Fi / Ethernet dongle
K	5/16-18UNC Battery connection terminals
L	PV connection terminal block
M	NEUTRAL Busbar
N	Communication connection ports (RS485, BMS, DRM, CT, DRY, RSD, PARA)
O	GROUND Busbar

1.2 Specifications

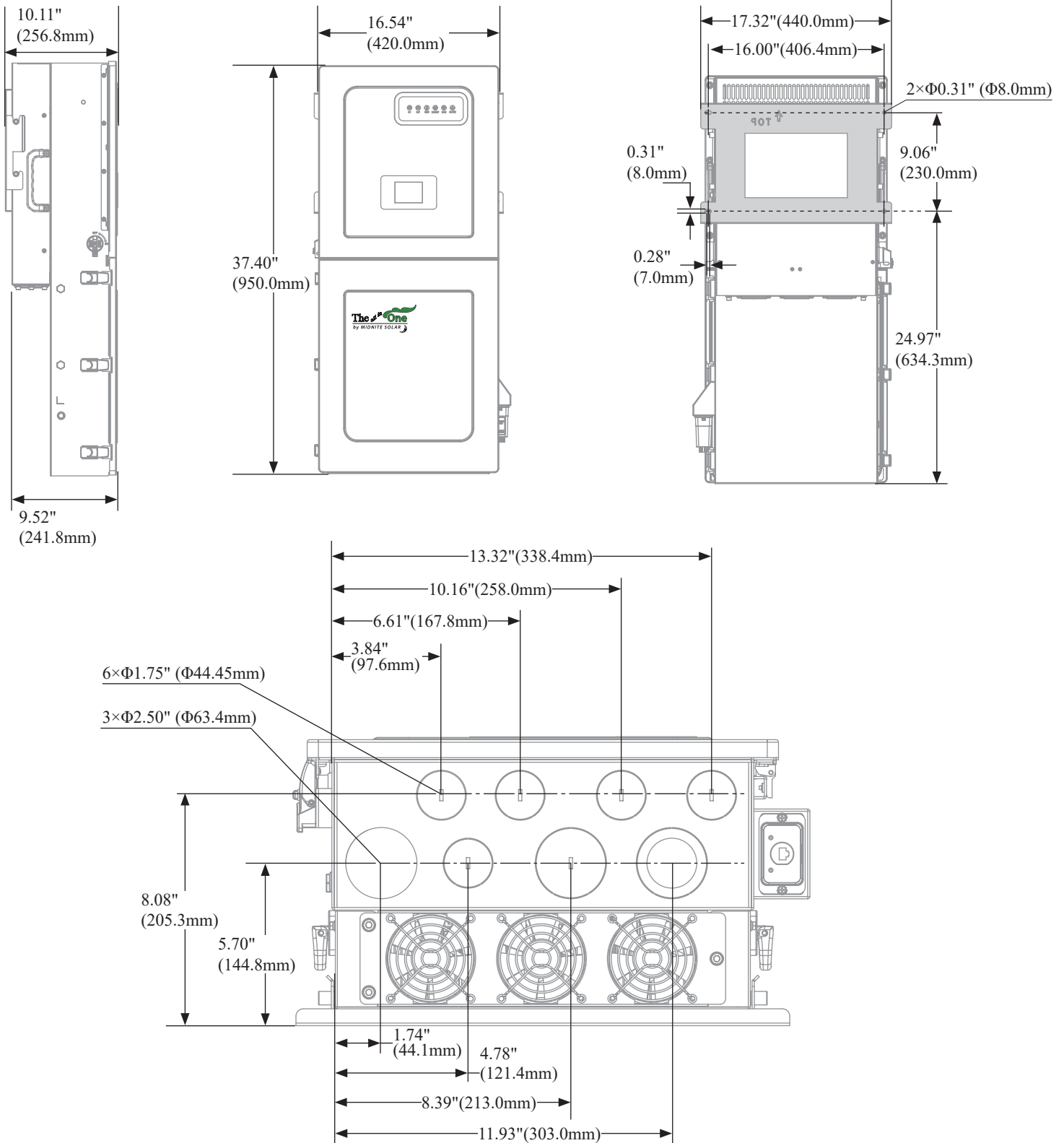

Terminal	Torque [in-lb]	Torque [Nm]
LOAD(#1/#2/#3/#4)	20 in-lb	2.5 Nm
Smart loads breaker/Gen input/AC coupling	20 in-lb	2.5 Nm
AC out	35 in-lb	4 Nm
Neutral / Ground (Busbar)	50 in-lb (7/16-20 UNF) / 26 in-lb (1/4-28 UNF)	5.6 Nm (7/16-20 UNF) / 2.9 Nm (1/4-28 UNF)
AC Input Grid	35 in-lb	4 Nm
Battery Connection	126 in-lb	15 Nm

1.3 Wire Gauge Guide

1. AC Input/Outputs:

- “AC INPUT GRID” Terminal 100A MAX passthrough, 2 AWG conductor.
- “AC OUTPUT” Terminal 100A MAX passthrough, 2 AWG conductor.
- Backed up Sub-panel may have more than 100 amps of load circuits although the utility pass through current is limited to 100 amps continuous per leg. Inverter output current when inverting is limited to 47.5 amps continuous per leg

 Wire gauge should be selected in compliance with your local electrical code

2. SENSORS CT: 16.40 ft [5 m] included.

3. BATTERY CABLES: 4/0 AWG THHN / Max Charge and Discharge limited to 260A

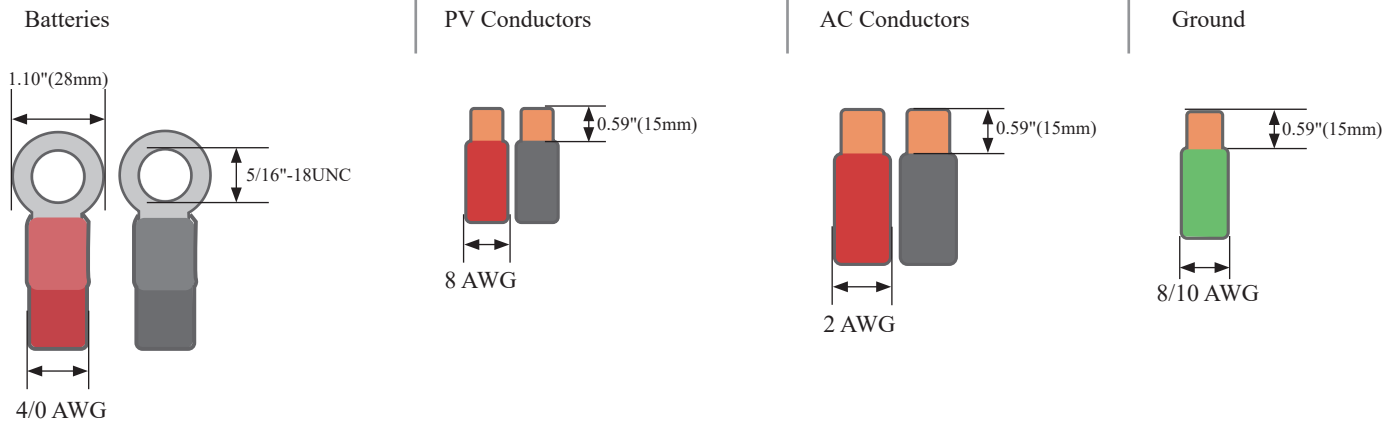

CT Sensors (Included)

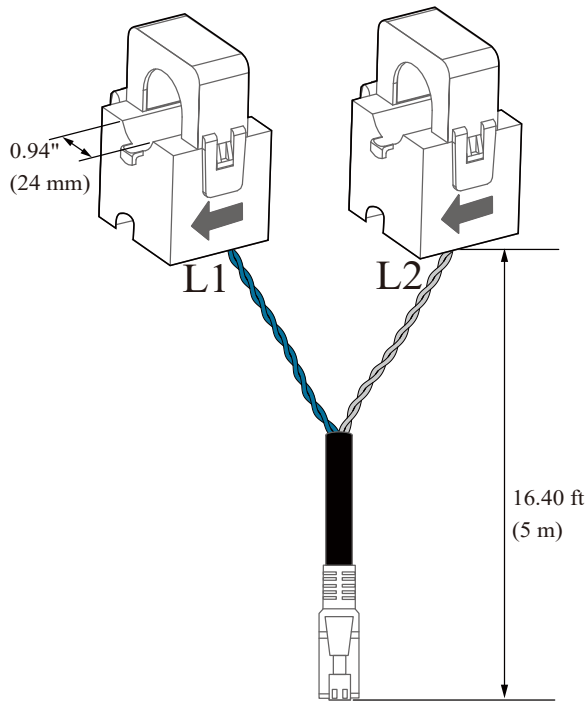

Ground Toroid (φ30mm)

The ground cable of the Grid needs to be wrapped around the toroid twice, as shown below.

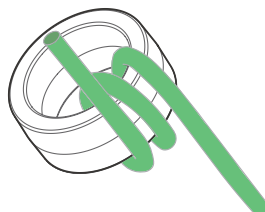

2. Installation

2.1 Mounting the MN MN 15-12KW-AIO

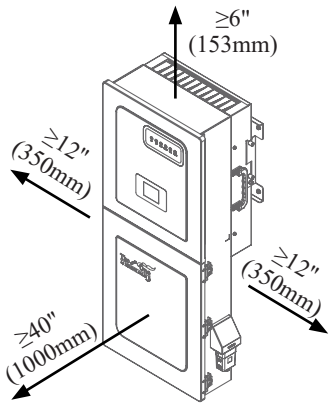

A. The system weight is 101.85 lb.(46.2 Kg).

B. Considering the dimensions of the inverter, find a suitable location for the system(s). There must be at least 6 in [15 cm] of vertical clearance for proper heat dissipation.



Heat transfer and cooling is done from bottom to top at a rate of 525W/hr

C. The MIDNITE MN MN 15-12KW-AIO is a NEMA 3R - IP65 enclosure that is rated for outdoor installation but can also be installed indoors.

D. ⚠️ PROTECT THE LCD SCREEN from direct exposure to UV light.

E. Mount the MIDNITE and ensure the unit is level and properly seated.

F. Securely attach the inverter to the mounting surface. You may need expansion plugs or anchors for concrete. In case a different anchorage is required, calculate the support needed to properly hold the weight of the equipment.

G. Remove the sticker on the bottom of the equipment before mounting. Use gutter template to mark the installation location on the wire guard.

$4 \times \Phi 0.18"$ (4.5mm) $\downarrow 2.30"$ (60mm)

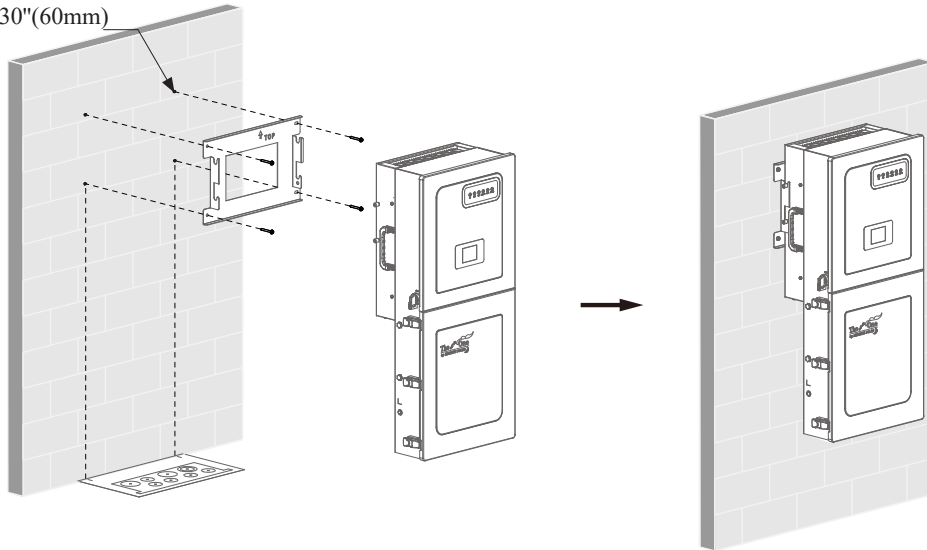

H. Knockout holes use bushing rings as needed.

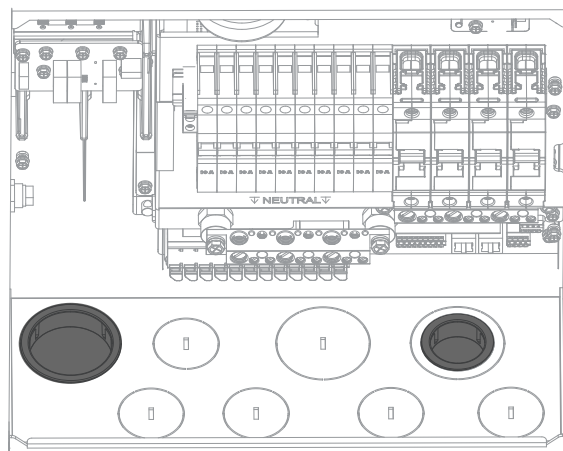

I. Mount the inverter in the optimal orientation as shown below.

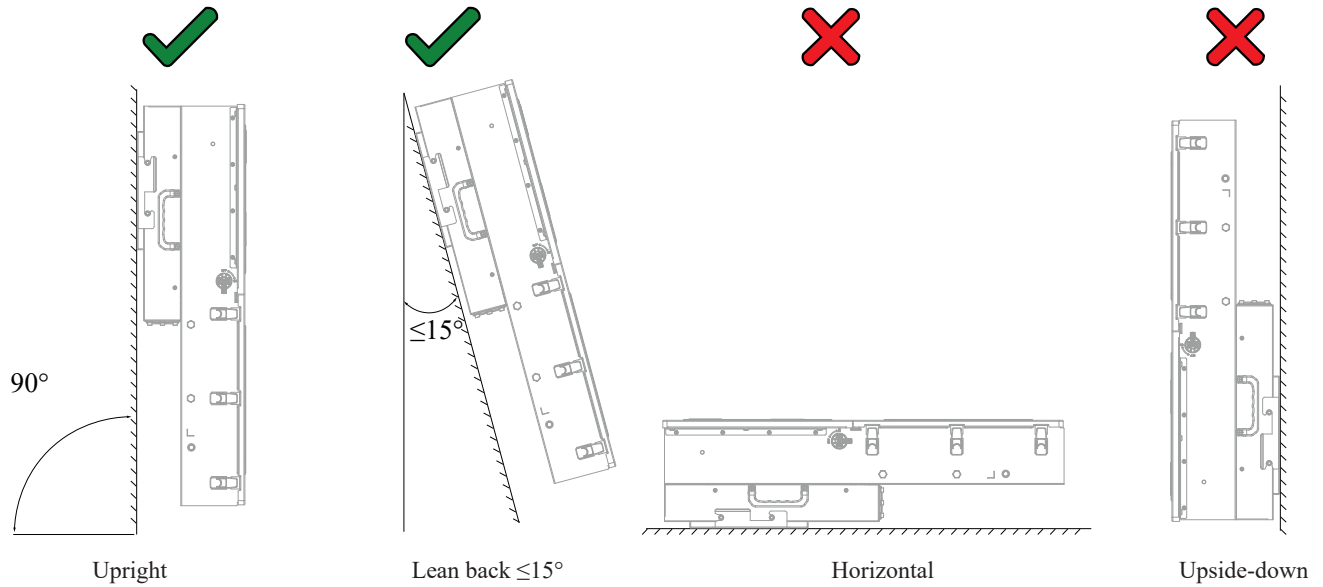

2.2 Connecting PV Modules



The inverter has 3 independent MPPTs and each can handle up to 2 PV strings. Each MPPT can operate at a current of 30A/22A/22A (self-limiting) and a MAX Voc of 600V.

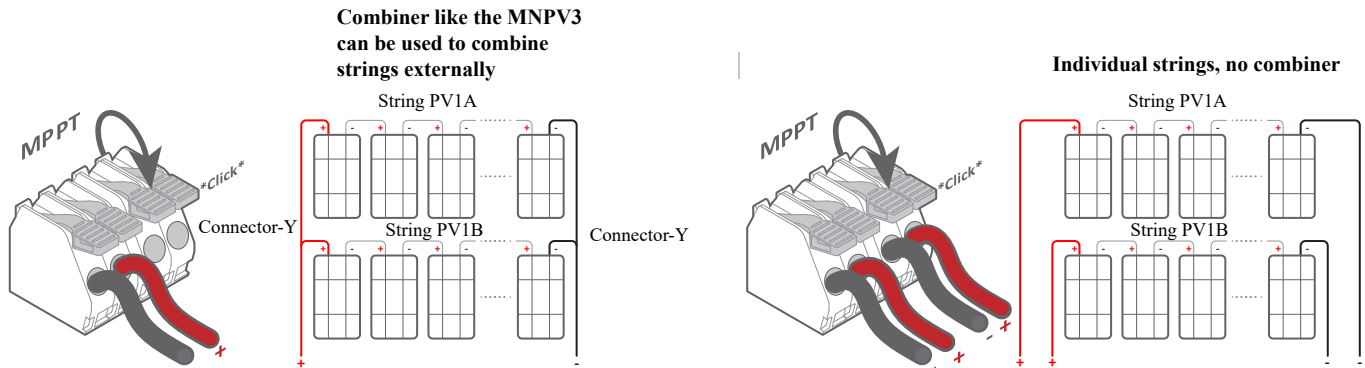

2.3 Integrating Batteries

Battery Toroid

Install the battery toroid (provided) on battery input wires, as shown in the following figure. Battery (+) and (-) cables must go through the toroid simultaneously. These toroids are for EMI suppression.

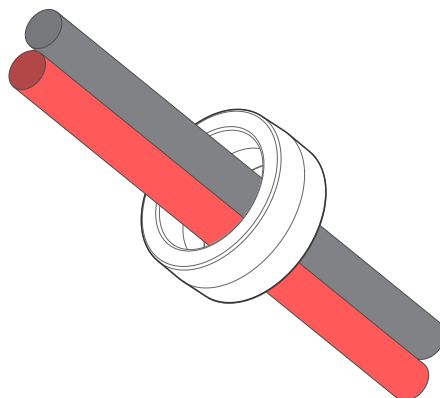

2.4 BMS Port (CAN/RS485, Only for Lithium Battery)

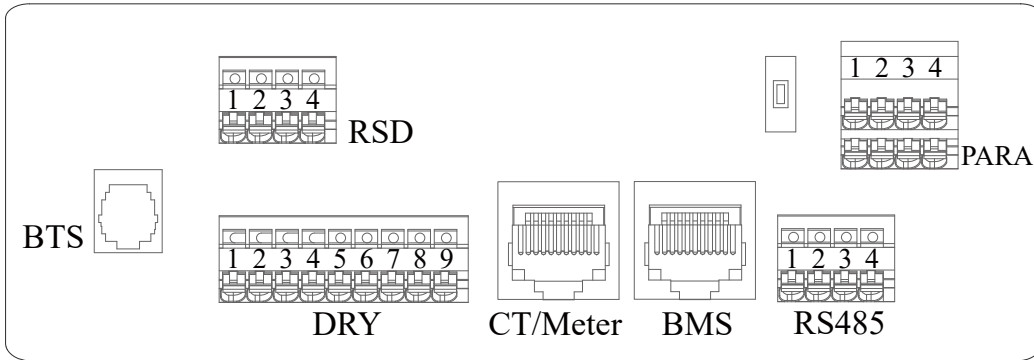

- **BTS:** Battery temperature sensor, not polarity sensitive. Used for voltage compensation for Lead Acid batteries. The standard MidNite MNBTS.
- **RSD:** Normally open dry contact for EPO (emergency power off). The built in transmitter is Sunspec compatible. MidNite Solar manufacturers String level Sunspec receivers that work with this inverter.
- **DRY:** Generator control, Remote off control, DI/DO control.
 - (1,2): Normally open relay for generator two-wire start.
 - (3,4,5,6): DI/DO control. (Digital input/output) Programmable through your App.
 - (7): Remote off control.
 - (8,+9): Temperature sensor terminal of lead-acid battery.
- **CT/METER:** CT/Meter communication or Grid current sense.
- **BMS:** Lithium battery communication interface.
- **PARA:** Parallel communication. A matched resistance switch for parallel communication.
- **RS485:** RS485 communication.

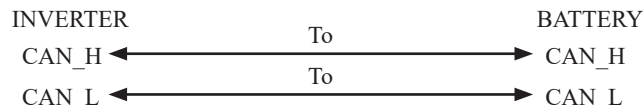

This manual ONLY illustrates the pinout sequence of BMS at INVERTER SIDE. For details about the pinout sequence at battery side, see the user manual of the battery you use.

Pin	RS485	CAN
1	RS485_A	--
2	RS485_B	--
3	GND_S	GND_S
4	--	CAN_H
5	--	CAN_L
6	GND_S	GND_S
7	GND_S	GND_S
8	GND_S	GND_S

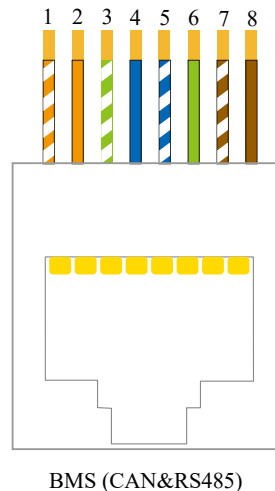

2.5 Wi-Fi / Ethernet Antenna (Dongle)



The appearance of actual modules may be slightly different. The figures shown here are only for illustration. For details, please refer to the corresponding Module Installation Guide in the packing.

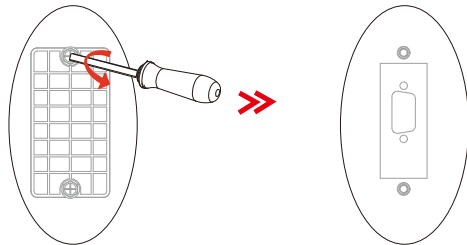

1. Unscrew and remove the cover.

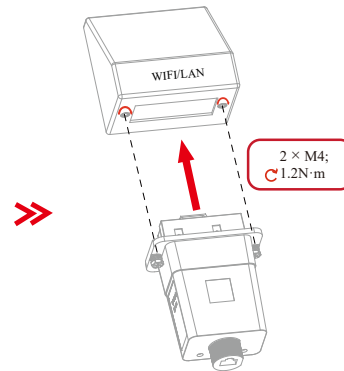

2. Install the module.

2.6 Limit Sensors (CT/Meter)

CT Sensors for Stand-alone application 120V/240V Split phase

Each inverter will include two CT.

Pin	Function Description
1	--
2	--
3	RS485_A
4	RS485_B
5	CT2-
6	CT2+
7	CT1+
8	CT1-

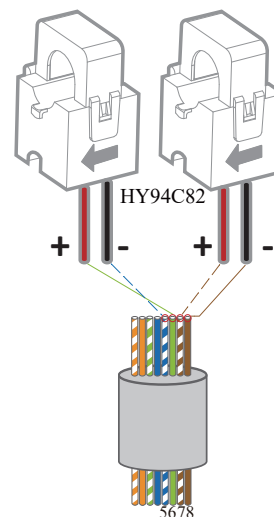

CT+Meter for Parallel Systems 120V/240V Split phase

- CT+meter sensors are essential for stacking is highly recommended for multi-system installs.
- Please contact sales at 360-403-7207 to purchase the meter and bigger CT.

Pin	Function Description
1	--
2	--
3	RS485_A
4	RS485_B
5	--
6	--
7	--
8	--

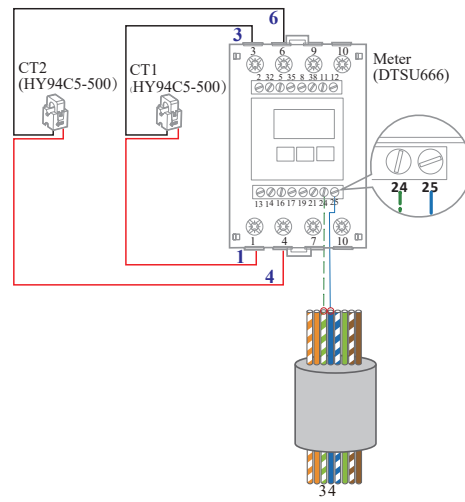

CT+Meter for Parallel Systems 120V/208V Three-Phase

- The three-phase system requires three CTs and 1 meter.
- Please contact sales at 360-403-7207 to purchase the meter and bigger CT.

Pin	Function Description
1	--
2	--
3	RS485_A
4	RS485_B
5	--
6	--
7	--
8	--

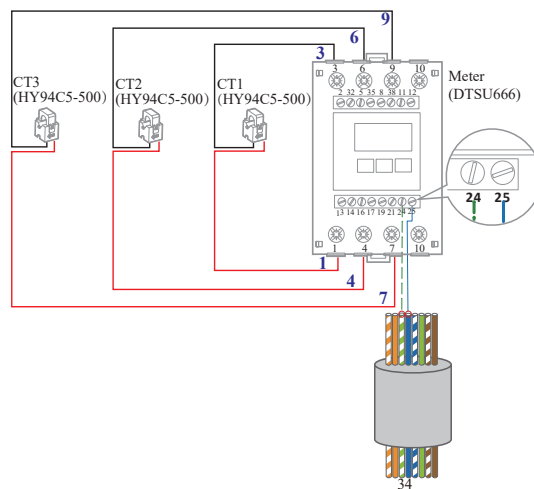

2.7 Parallel Communication

It is necessary to turn the matched resistance switch of No. 1 inverter and No. N inverter to “ON” in parallel connection mode.

Pin	Function Description
1	GND_S
2	PARA_SYNC
3	CAN_L
4	CAN_H

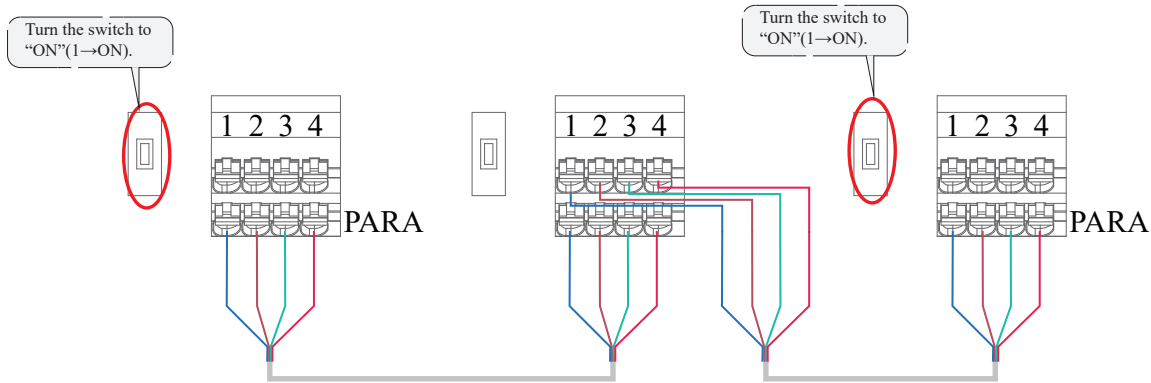

2.8 Power ON MIDNITE MN MN 15-12KW-AIO

- Power on the PV.
- Power on the battery from the battery breaker and any external battery switches or breakers.
- Power on the AC IN GRID breaker.
- Connect the cell phone App via Bluetooth. And click the Power ON in the App for the first time. Or you can hold the ON/OFF button on the side of the inverter for 5s in this step when performing subsequent startup. Cell phone app instructions are on the side of the inverter & on the quick start guide.
- Power on the AC OUT breaker.
- Power on the SMART LOAD breakers
- Please wait 5 minutes for the inverter to start as it makes systems checks.**
- When changing modes or changing smart load settings, you must put the inverter in standby and wait 5 minutes to restart.**
- If an error is identified, you must clear the error to recover and wait 5 minutes to restart.**

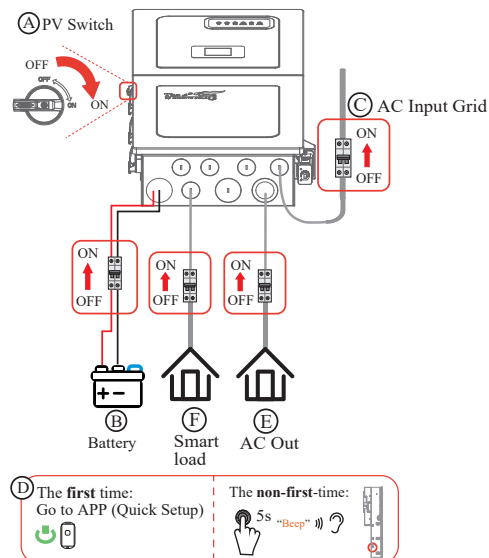

2.9 Power Off Sequence

- A. Power off the AC OUT breaker.
- B. Power off the SMART LOAD breakers
- C. Connect the cell phone App via Bluetooth. And click the Power OFF on the App. Or you can hold the ON/OFF button on the side of the inverter for 5 seconds in this step when performing subsequent shutdown
- D. Power off the AC IN GRID breaker.
- E. Power off the battery from the battery breaker and any external battery switches or breakers.
- F. Power off the PV.
- G. To disconnect the inverter cables, please wait at least **5 minutes** before touching them.

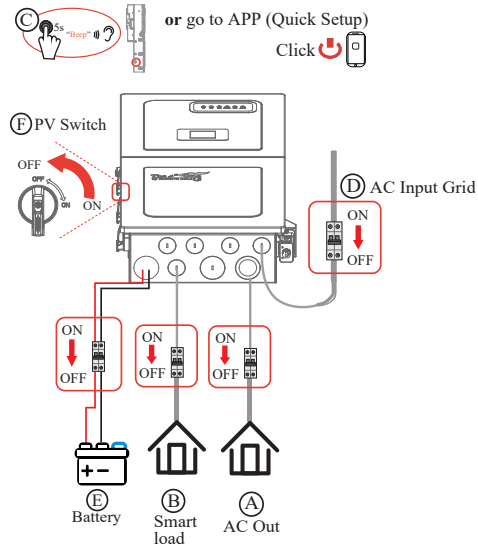

3. App Setting Guide

Download App for Local Setting

- Scan the QR code to download the App MidNite Pro.



- Download the APP from the App Store or Google Play

Access Permission

Before using the local setting, the APP should access some permissions. (You can allow them when you install the APP or grant permissions in your own phone setting.) When the APP asks for permission, please click Allow.

Connect Inverter

Firstly, open the bluetooth and the APP on your phone. Then connect the inverter.

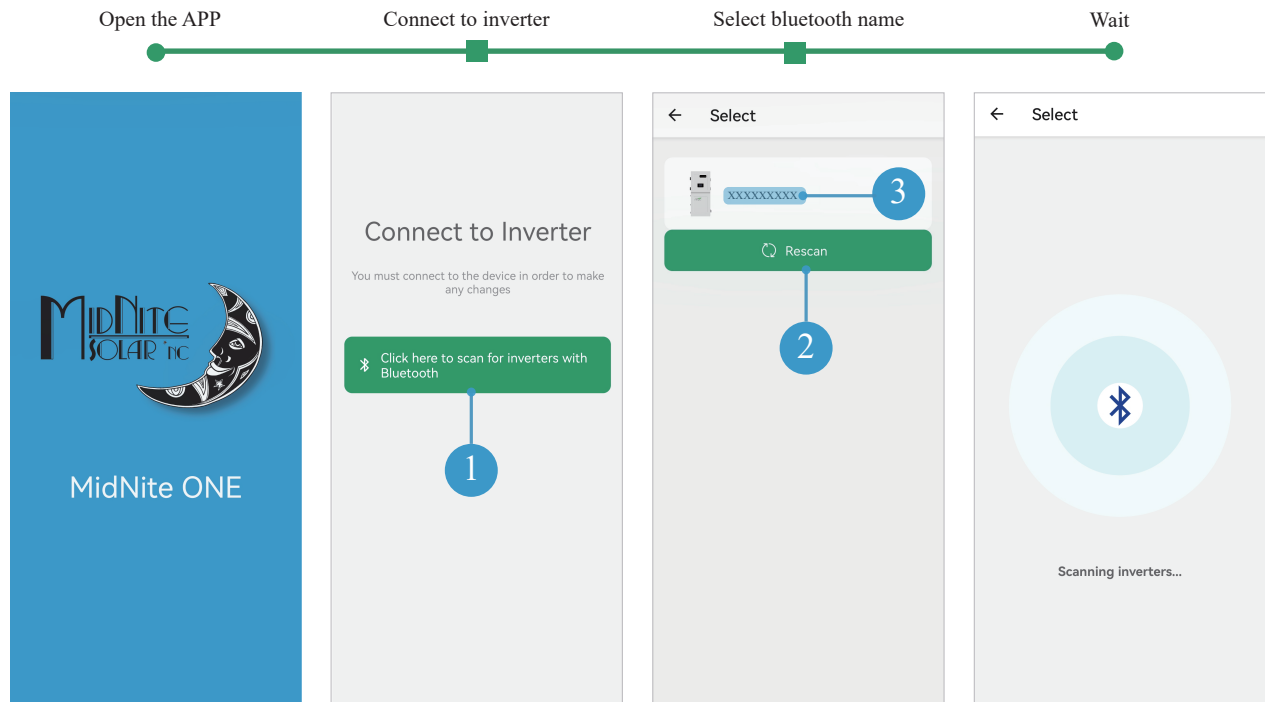

3.1 Installer login

Select the installer role to log in.

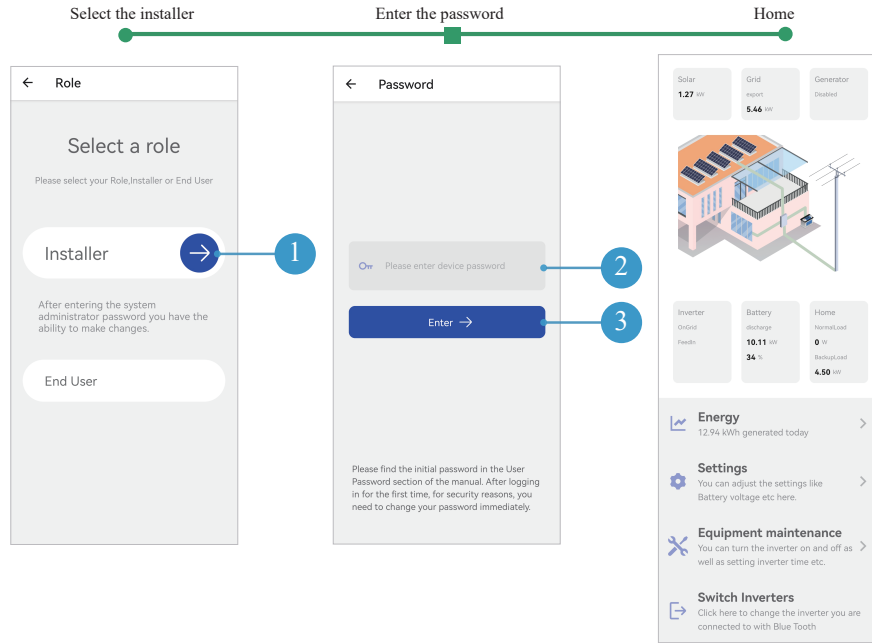

3.2 Stored energy

- A. Set the work mode.
- B. If the user want to sell back, please disable the Zero Export button.
- C. Set the related battery parameters.

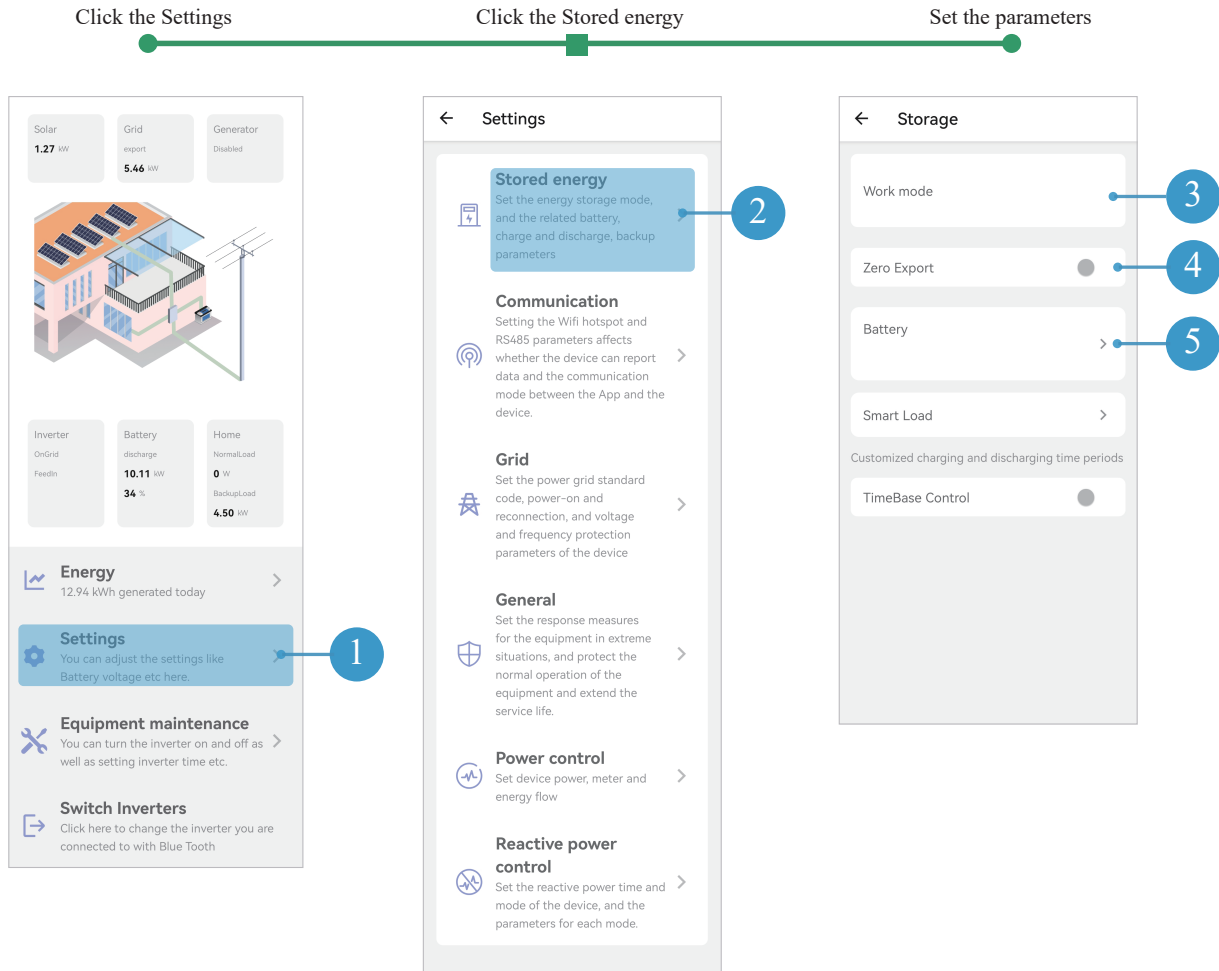

3.2.1 Work Mode: Self Consumption

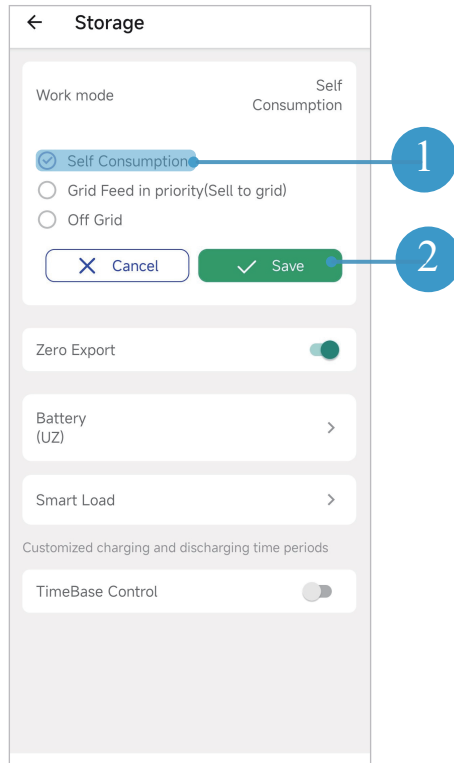

3.2.2 Work Mode: Grid Feed in priority(Sell to grid)

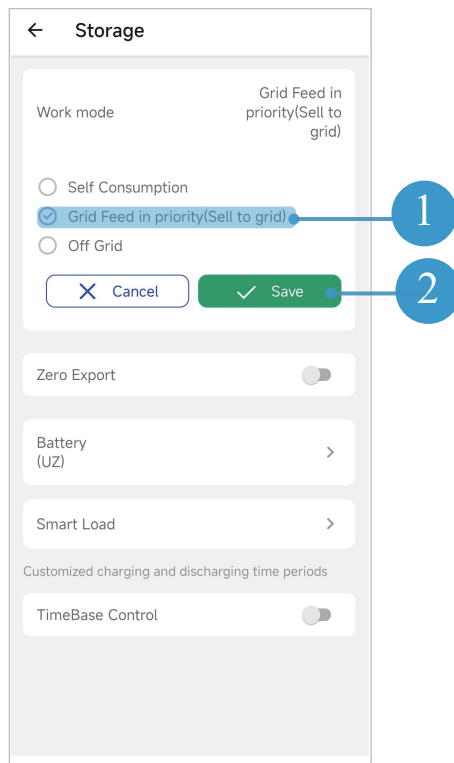

3.2.3 Work Mode: Off Grid

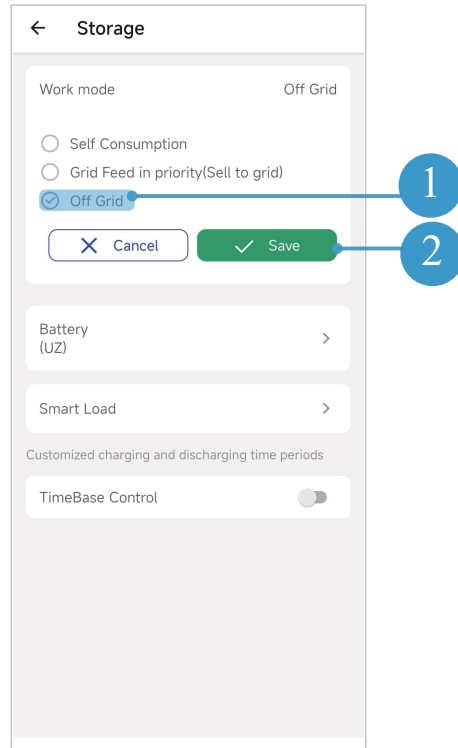

3.3 Communication

Connect to the router.

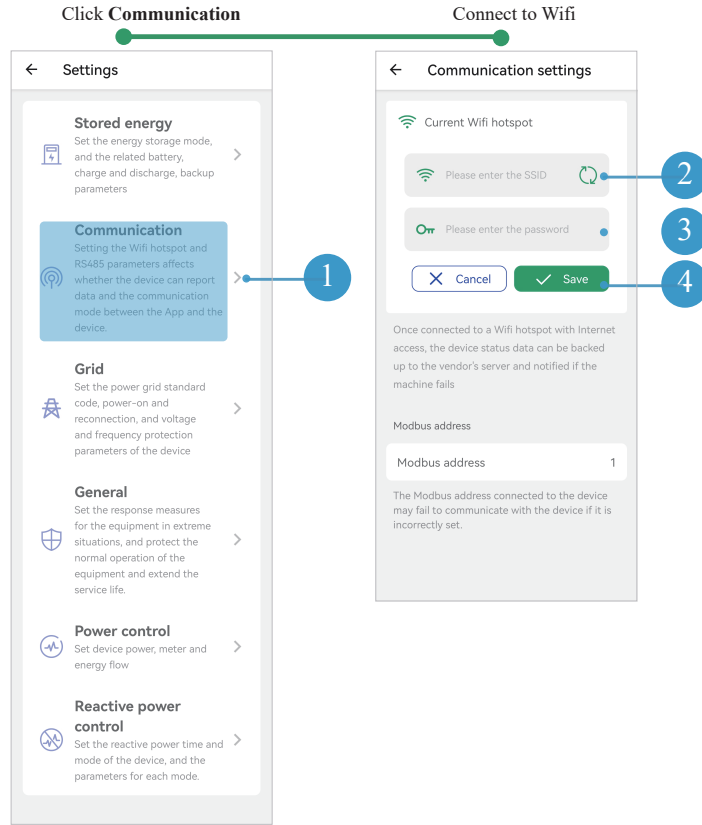

3.4 Grid

Set the grid parameters.

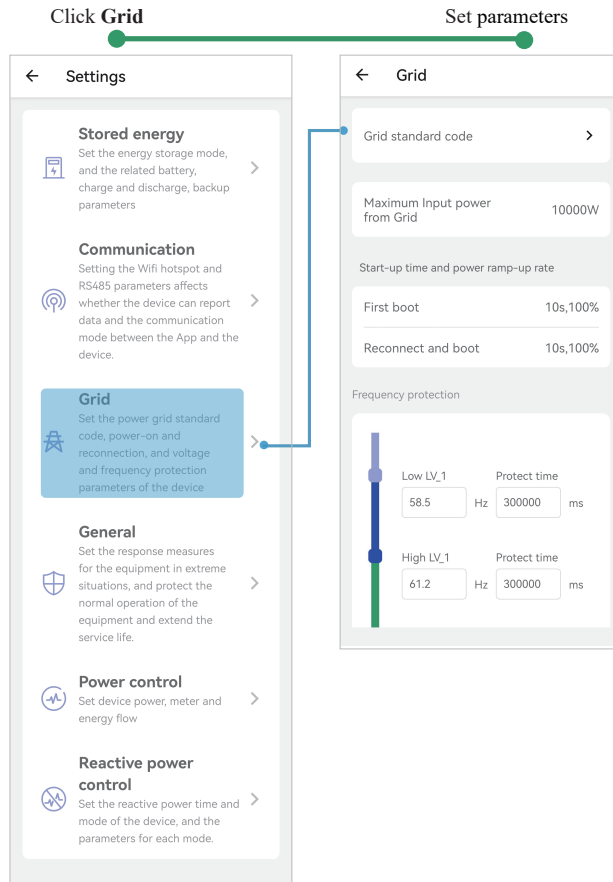

3.5 Power control

Set the power control parameters .

Click **Power control** → Set parameters

Settings

- Stored energy
- Communication
- Grid
- General
- Power control** (1)
- Reactive power control

Power Control

- Power Control
- Sensor location
- Energy flow directions (2)
- Power derating control method
- Maximum feed in grid power
- Maximum permit consumption from Grid

3.6 Equipment maintenance

Click **Equipment maintenance** → Synchronize date and time, then click the button

Equipment maintenance (1)

Maintenance

Basic Information

Device model	SN
MNAIO-10K	2405-30220094PH
Master DSP Version	Slave DSP Version
010010	010005
CSB version	DC-DC MCU version
010109	
APP version	
1.0.3	

View main parameters

View device logs

Clear all data

Maintenance operations

- Device time 2024-03-19 16:15:30 (2)
- Reset

Click Sync Time and the device time will be set to be the same as the phone time.

Restore the device to factory condition, please shut down before operation

Click the button to turn the device on/off (3)

4. Wiring Diagrams



These wiring diagrams are examples for common inverter installation. Diagrams must meet local electrical code and authorized jurisdiction requirements.

MIDNITE MN 15-12KW-AIO
Standard Wiring Diagram

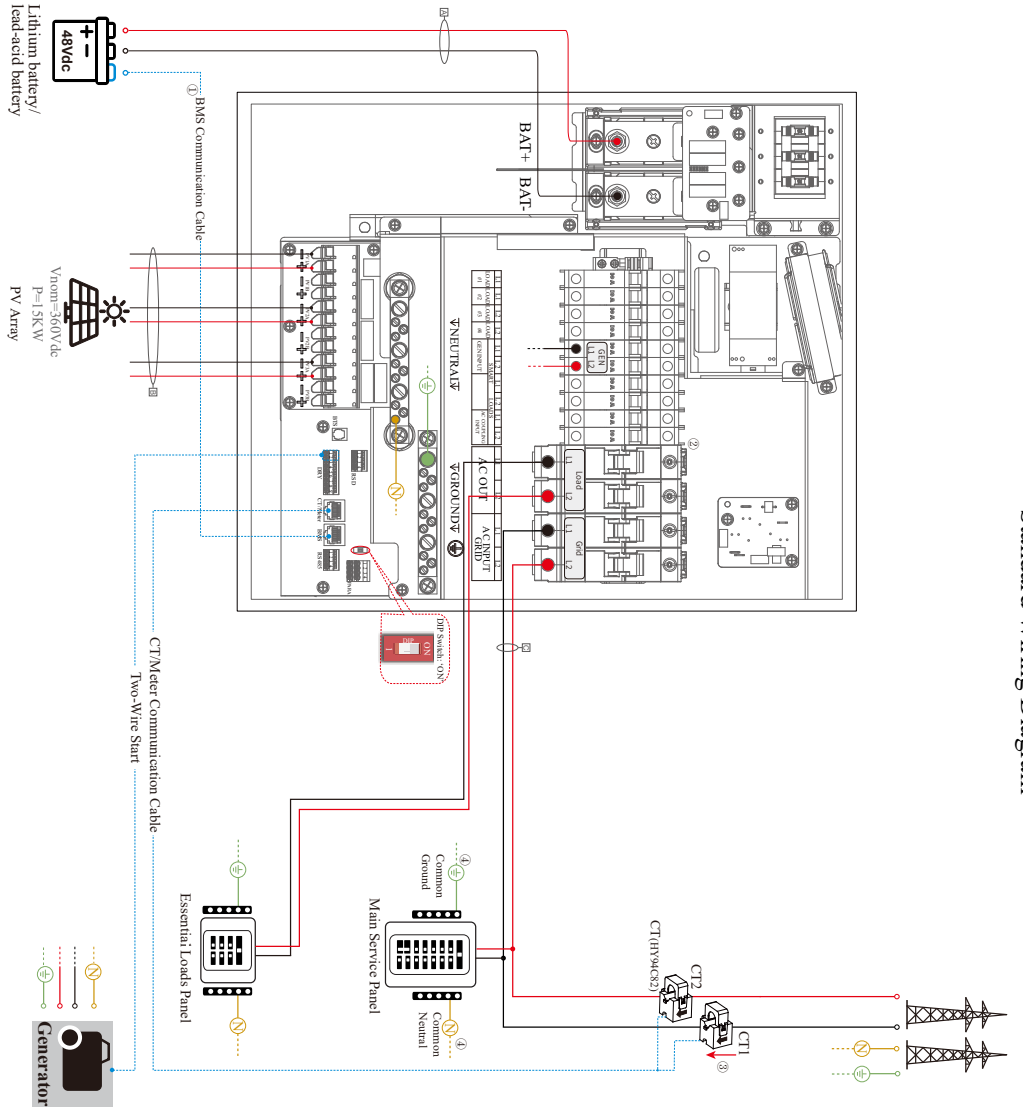

- ① BMS is only for lithium battery. When applying standard lithium battery connection, each inverter should be connected to BMS COM cable.
- ② The DC/AC breaker specification please refer to LABEL.
- ③ The DC/AC breaker specification please refer to LABEL.
- ④ ⚡ These symbols represent a common neutral/ground connection.

- (AC) L1
- (DC) PV-
- (DC) BAT-
- (AC) L2
- (DC) PV+
- (DC) BAT+
- NEUTRAL
- GROUND
- COM

TABLE 1
BREAKER SPECIFICATION

LOCATION	SPECIFICATION
Battery side(DC)	300A/80VDC
GEN side(AC)	60A/120/240VAC
Smart loads	30A/120/240VAC
AC Coupling	50A/120/240VAC
AC in Grid/AC out	100A/120/240VAC
Load 1 L2/Load 2 L2/Load 3 L1	15A/120VAC
Load 4 L1	20A/120VAC
Normal load side(AC)	Depends on required pass-through current and local code requirements

TABLE 2
WIRE GAUGE GUIDE (COPPER)

LABEL	CONDUCTOR
A	4/0 AWG
B	8 AWG
C	2 AWG

Diagram 01

MIDNITE MN 15-12KW-AIO Standard Wiring Diagram - 2<N≤5 Parallel Inverters | 120/240V

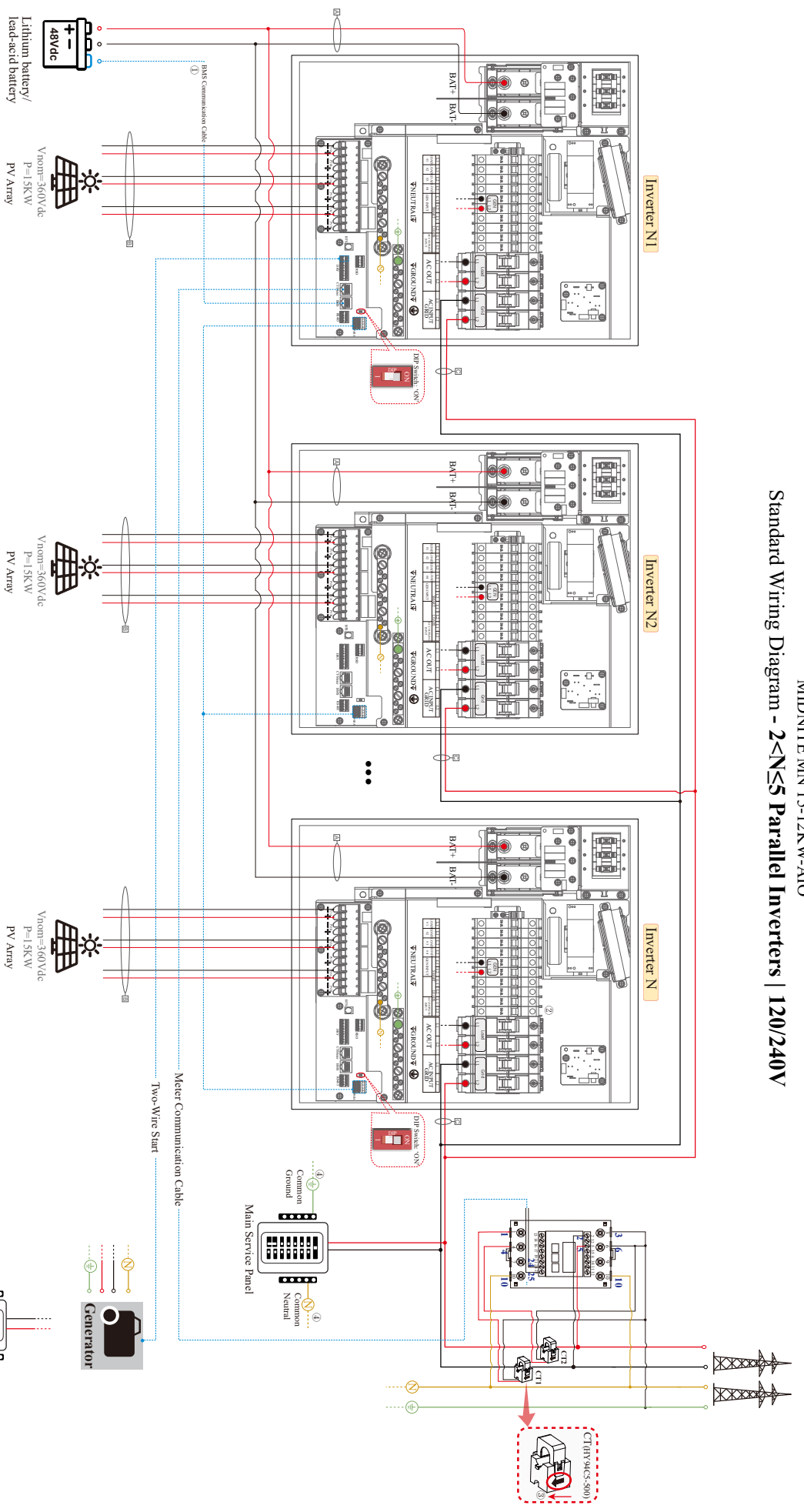

- ① (A)O/L1 (DC) PV-
 - ② (A)O/L2 (DC) PV+
 - ③ NEUTRAL
 - ④ GROUND
 - ⑤ COM
- ① BMS is only for lithium battery. When applying standard lithium battery connection, each inverter should be connected to BMS COM cable.
 ② The DC AC breaker specification please refer to TABLE 1.
 ③ CT is optional. If you need to monitor the inverter AC output, please refer to the CT specification.
 ④ These symbols represent a common neutral/ground connection.

TABLE 1
BREAKER SPECIFICATION

LOCATION	SPECIFICATION
Battery side(DC)	300A/80VDC
GEN side(AC)	60A/120/240VAC
Smart loads	30A/120/240VAC
AC Coupling	50A/120/240VAC
AC in Grid/AC out	100A/120/240VAC
Load 1 L2/Load 2 L2/Load 3 L1	15A/120VAC
Load 4 L1	20A/120VAC
Normal load side(AC)	Depends on control panel/breakthrough cabinet and panel load requirements.

TABLE 2
WIRE GAUGE GUIDE (COPPER)

LABEL	CONDUCTOR
A	4/0 AWG
B	8 AWG
C	2 AWG

Diagram 02

NOTE

The *all in* **One**

by MIDNITE SOLAR 