



14000 Burn Rd  
Arlington, WA 98223  
USA  
Ph (425)374-9060  
www.midnitesolar.com

## C Series Power Back Up Instructions



### The MidNite Solar C Series Power Back Up System

The C Series Power Back up system is designed and manufactured for by MidNite Solar, Inc. Years of power back up experience are cumulated into this integrated power back up system. The basic system consists of three main components; Batteries, inverter/charger and electrical distribution panel. Each of these components have been selected and designed to work homogenously to provide you with the utmost in power back up.

The installation of the Power System is very simple although it is highly recommended that a licensed electrician make all the necessary connections. Check with state and local codes for applicability. Wiring methods in accordance with the National electrical Code, ANSI/NFPA 70 are to be used.

The photo above right shows the Power System as it is received. The batteries are to be installed on site due to weight and shipping constraints. The Power System is intended to use industry size Group 31 sealed AGM batteries. Group 31 AGM (absorbed glass matte) batteries are rated at 105 amp hours at 12 volts DC. No venting is required since sealed batteries do not gas.

# C Series Power Back Up Instructions (continued)

## IMPORTANT SAFETY INSTRUCTIONS

### SAVE THESE INSTRUCTIONS

**A.** This manual contains important instructions for models MNBE-C,-C1 and -C2 that shall be followed during installation and maintenance of the afore mentioned model numbers.

**B.** Use 6AWG THHN or equivalent wire for AC connections to this system. Battery and inverter DC wiring is provided with this enclosure. Optional PV wiring shall be THHN or equivalent wiring of the appropriate size.

**C.** Torque the AC input/output terminal block to 30-35 inch pounds. Torque the din rail mount load circuit breakers to 20 inch pounds and then re-torque after one hour.

**D.** The following symbols may be used in or on this product.

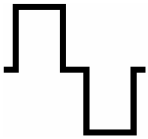

Modified waveform



Sine wave waveform

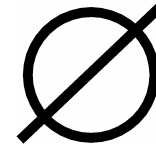

Single phase

**E.** Use copper conductors only

**F.** This system is designed to use two 12 volt sealed AGM batteries in series to result in a 24 volt DC battery supply. There are four such 24 volt strings in this enclosure.

**G.** Use 6AWG THHN wire for field wiring to connect to the AC circuits of this system.

**H.** Install a 60 amp 120/240VAC circuit breaker to protect the AC input wiring to this system.

**I. WARNING** To reduce the risk of fire, do not connect an AC load center (circuit breaker panel) having multiwire branch circuits connected.

### Enclosure mounting:

The C Series Power System is supplied with floor mounting flanges on each side of the cabinet. It is advisable to use these four 3/8" diameter holes to bolt the cabinet down to the floor. The cabinet can also be secured to a wall by drilling through the back panel and through bolting to the wall. Securing the cabinet to a wall is important in areas prone to earth quakes. If the batteries are to be tied down to the shelves, use strapping (not supplied) that goes underneath each shelf. This must be installed on the bottom shelf prior to final placement and installation or access to the underside of the shelf will be blocked.

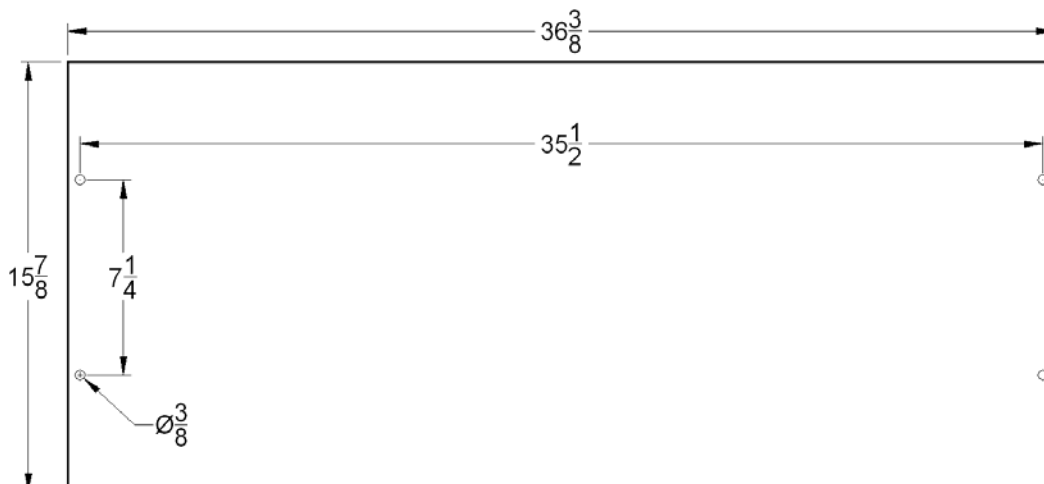

# C Series Power Back Up Instructions (continued)

## Foot print of C Series Power System

### Battery installation.

The primary Power System is designed to hold eight sealed Group 31 batteries. Do not attempt to use flooded non-sealed batteries in this enclosure. Flooded batteries create hydrogen gas and are not allowed per UL standards in an enclosure that can cause arcs or sparks. Relays inside of the inverter and circuit breakers on the control panel can cause arcs and sparks.

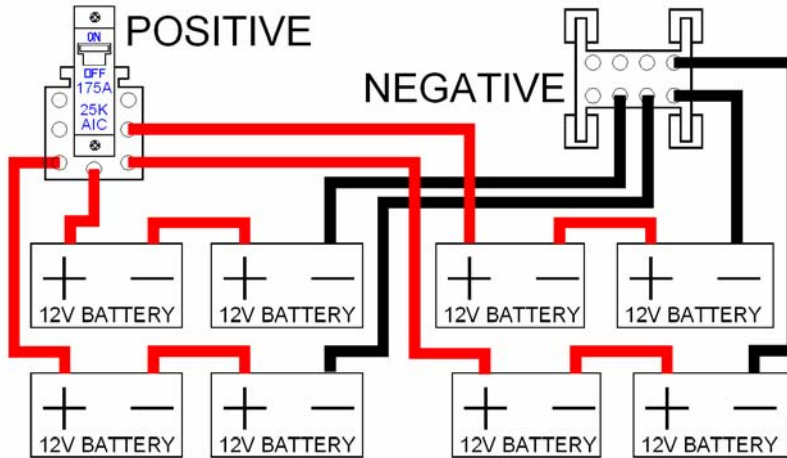

The Power System comes with all the cables necessary to complete the battery hook up as shown here. Make sure the breaker is in the off position before hooking up batteries. Add the short jumper cables last for safety reasons. The battery bank is essentially dead until the short series

connections have been made. Pay careful attention to polarity. Batteries have enormous amounts of stored energy and are very unforgiving if mistakes are made. Do not wear jewelry or watches when connecting batteries.

Placement of each cable to the bus bars is not critical. Use any of the studs provided in the bus bars.



Battery Bus bars are shown here with all cables for the main cabinet installed. Note that there are unused studs on each bus bar. The unused studs are used to interconnect additional “**Companion**” (C1) battery storage enclosures for extra run time. Companion battery storage enclosures come with a 250 amp disconnect and can be installed end to end on either side of the Power System. Turning off this disconnect allows the additional battery banks to be connected without live wires for safety. Two

## C Series Power Back Up Instructions (continued)

additional cabinets each with twelve batteries can be connected to the Power System. There are two 2" conduit knock outs on each side of the enclosures for interconnecting cables.

Each battery is rated for 105 amp hours at 12 volts. The batteries can effectively be discharged to 80% depth of discharge. At the 80% DOD, each battery stores 1008 watt hours of power.

The C Series Power System with eight batteries has an effective 8064 watt hour capacity.

The C Series Power System with one Companion (C1) enclosure has a 20,160 watt hour capacity.

The C Series Power System with two Companion (C1) enclosures has a 32,256 watt hour capacity.

Watt hours explained: 1000 watt hours of storage equals enough power to run a 1 watt load for one thousand hours, or 100 watts for ten hours or 1000 watts for one hour. As you can see, conserving power during outages will result in longer run times.

### AC connections:

One 3/4"/1" conduit knockout is provided on the rear of the cabinet as well as one on each side for AC input and output connections..



Photo of AC terminal block compartment

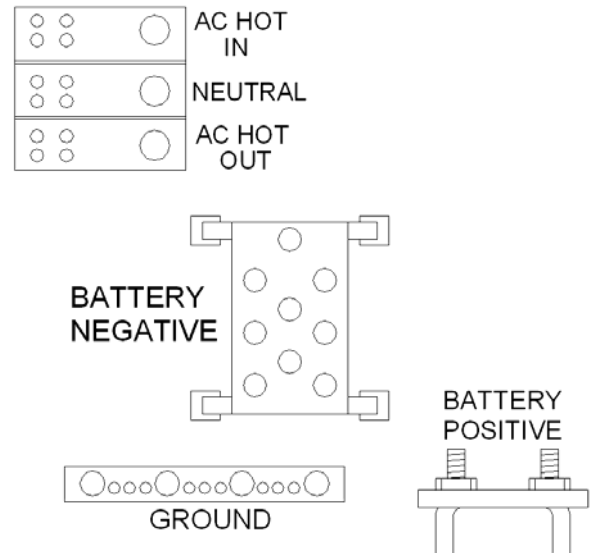

Drawing of terminal block and Ground placement

Refer to the wiring diagram at the end of these instructions for complete system schematic.

To understand how the C Series Power System hooks up, it is helpful to understand a couple of things regarding inverter back up systems in general.

1. An inverter/charger power back up system usually does not attempt to back up the entire house.
2. The inverter/charger is electrically located between the main service entrance breaker panel and the sub-panel breaker panel. The sub-panel in this case is located inside the Power System and has three 15 amp load circuit breakers. Twenty amp breakers are also available.
3. The inverter cannot invert and charge at the same time. The inverter actually runs backwards to charge.

You will need up to three AC wires plus ground in order to hook up the Power System AC section.

## C Series Power Back Up Instructions (continued)

Install a 6AWG black wire from a 60 amp circuit in the main service entrance to the Power System AC Hot Input.

Install a 6AWG white wire from the service entrance neutral to the power System Neutral terminal block.

Install a 6AWG ground wire from the service entrance ground to the Power System ground.

The load circuits can be wired two different ways. The Power System is provided with three 15 amp circuit breakers that are ready to supply the backed up circuits. You will need to remove the circuit breaker cover to gain access to the three branch circuit rated breakers supplied. Remove the three #10 pan head Philips screws that hold the cover on. Install your 14AWG wire to the top of the three load breakers and then reattach the circuit breaker cover. These load circuits will usually be circuits that used to be inside the main service entrance panel. You are merely moving the AC hot wire from one breaker panel to another.



This photo shows the breaker cover installed.

From left to right:

1. GFCI AC outlet for loads not hardwired.
2. AC Bypass switch. Use this when servicing the inverter or if it fails. The backed up load circuits will be connected to the main service entrance panel when in bypass mode.
3. AC input. This breaker feeds the input and charger of the inverter.
4. 15 amp breakers for GFCI outlet and backed up loads.
5. Four spare slots (for PV input).
6. Inverter battery breaker

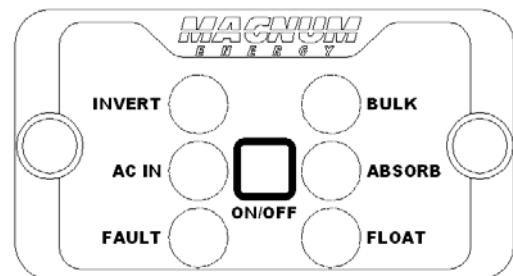

The Status module allows on/off operation

The invert light will glow when the inverter/charger is turned on.

The AC in light will glow when utility power is available. If the AC in light is not glowing, and you have power, the Power System is doing its job of providing power to the backed up load circuits.

