

QUAD SUNNY ISLANDS AC COUPLED AC and Communications Wiring

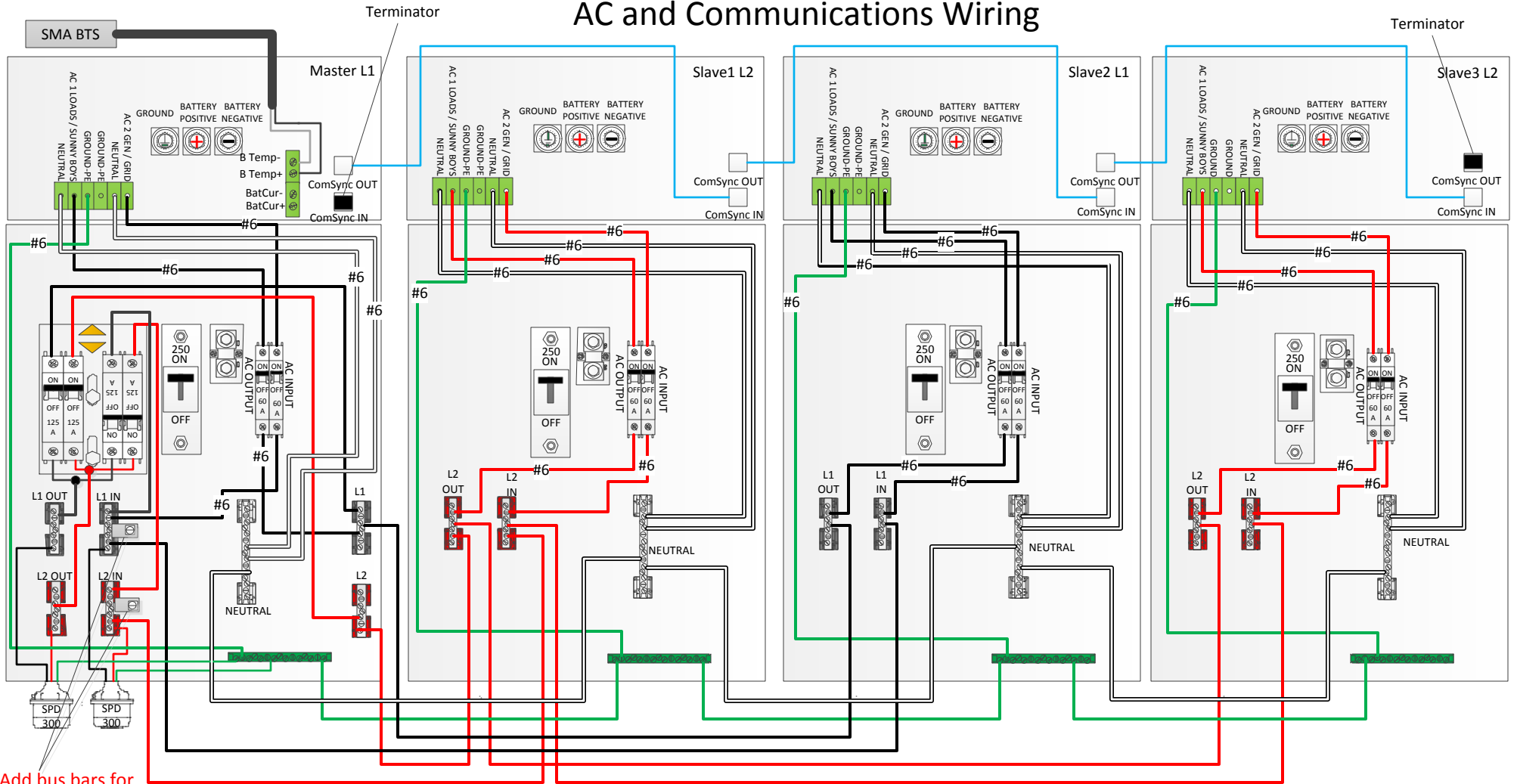

Add bus bars for
customers Large AC IN
wires

ALL AC WIRING IS #2 UNLESS MARKED OTHERWISE.

BASICALLY ALL WIRES FROM EACH INDIVIDUAL INVERTER WILL BE #6 AND ALL OTHERS ARE #2

DC WIRING by MidNite

**ALL CABLES 2/0
UNLESS MARKED.**

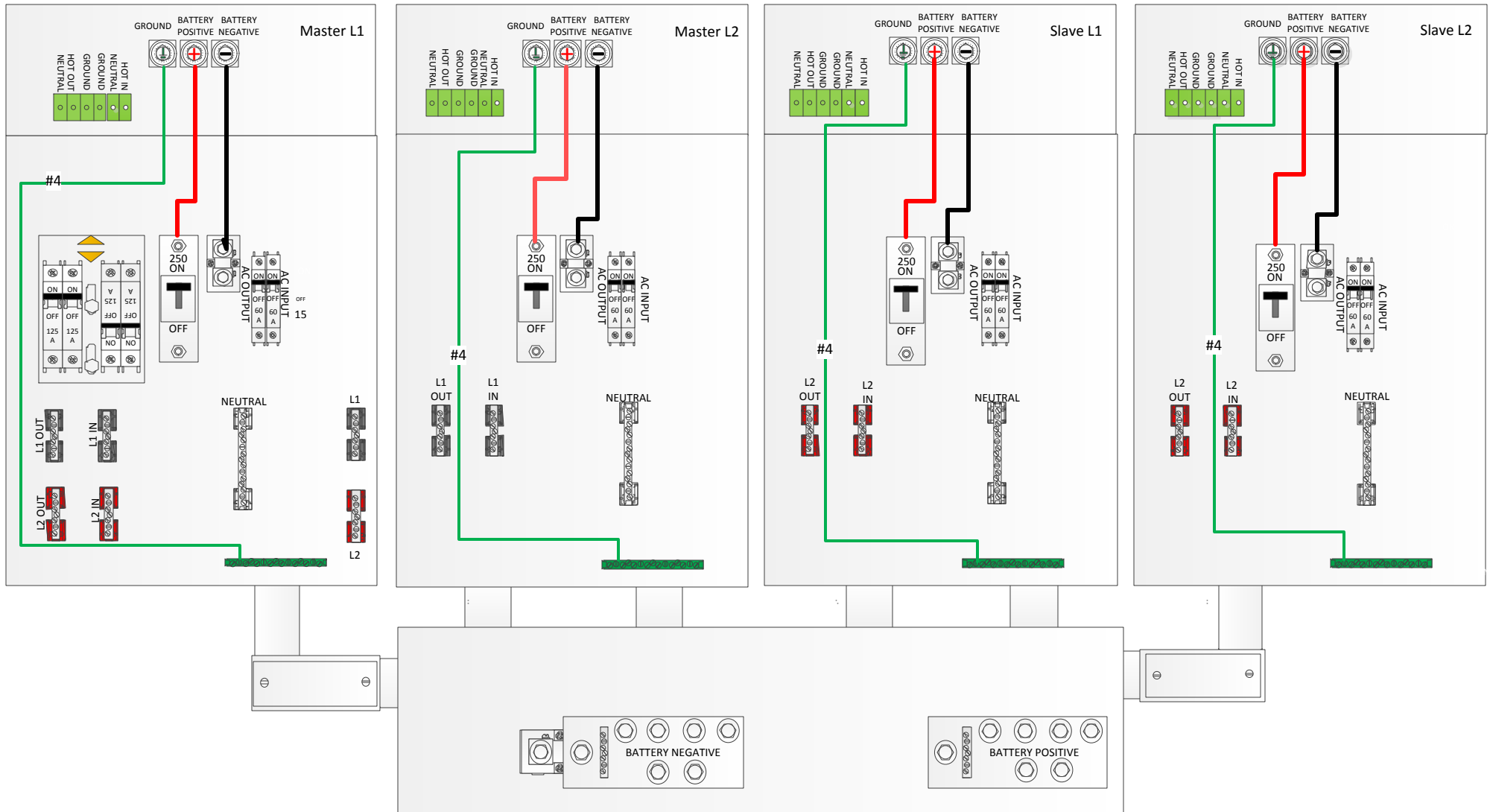

DC WIRING by Customer

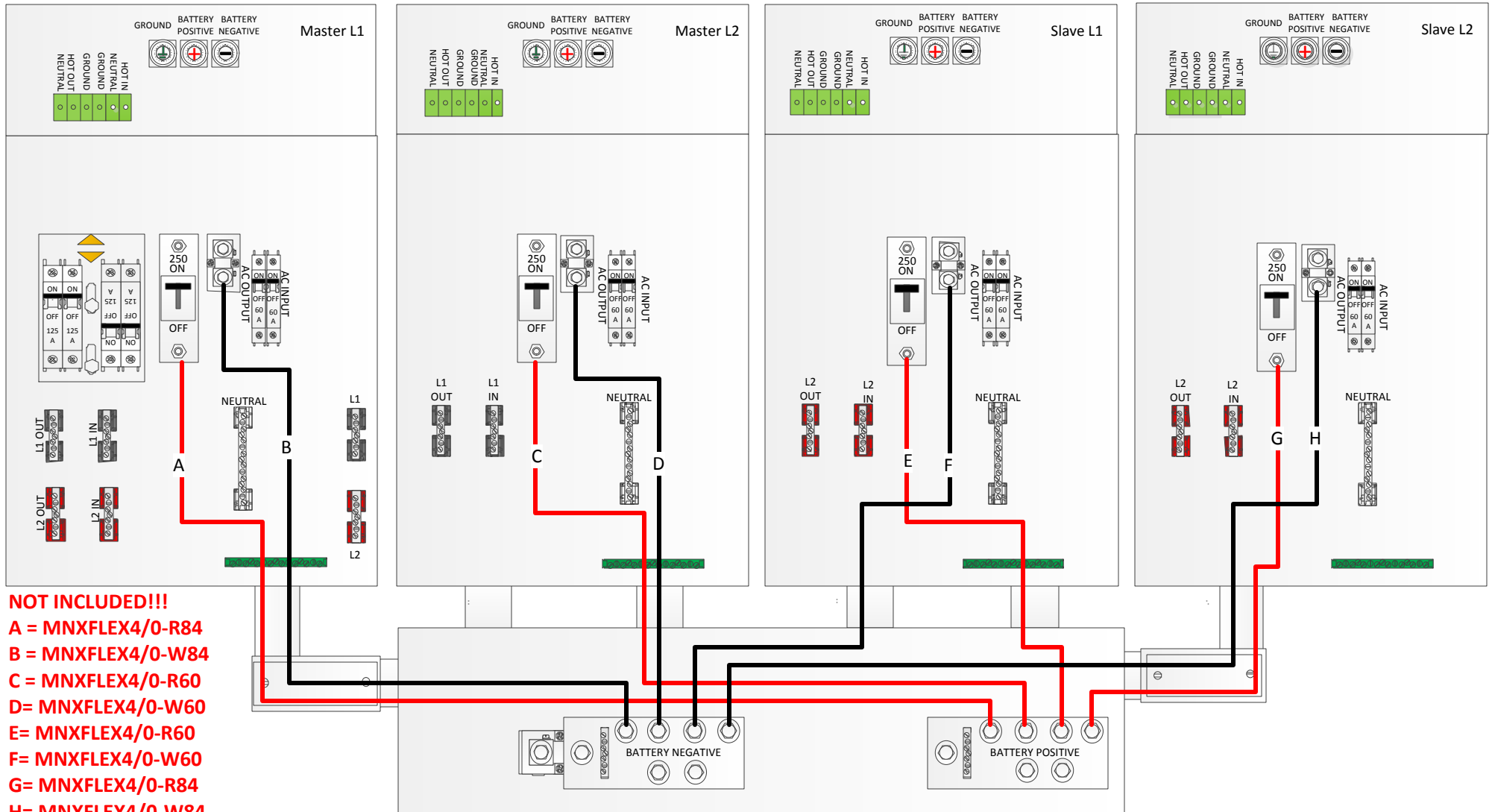

- NOT INCLUDED!!!**
- A = MNXFLEX4/0-R84
 - B = MNXFLEX4/0-W84
 - C = MNXFLEX4/0-R60
 - D = MNXFLEX4/0-W60
 - E = MNXFLEX4/0-R60
 - F = MNXFLEX4/0-W60
 - G = MNXFLEX4/0-R84
 - H = MNXFLEX4/0-W84

- NON INCLUDED CONDUIT PARTS:**
- 1 - 2 inch PVC LL
 - 1 - 2 inch PVC LR
 - 12 - 2 inch male adapters with lock nuts and bushings
 - 5-6ft of 2 inch schedule 40 PVC conduit

Customer Wiring

