

DUAL SUNNY ISLAND WITH 4 CLASSICS

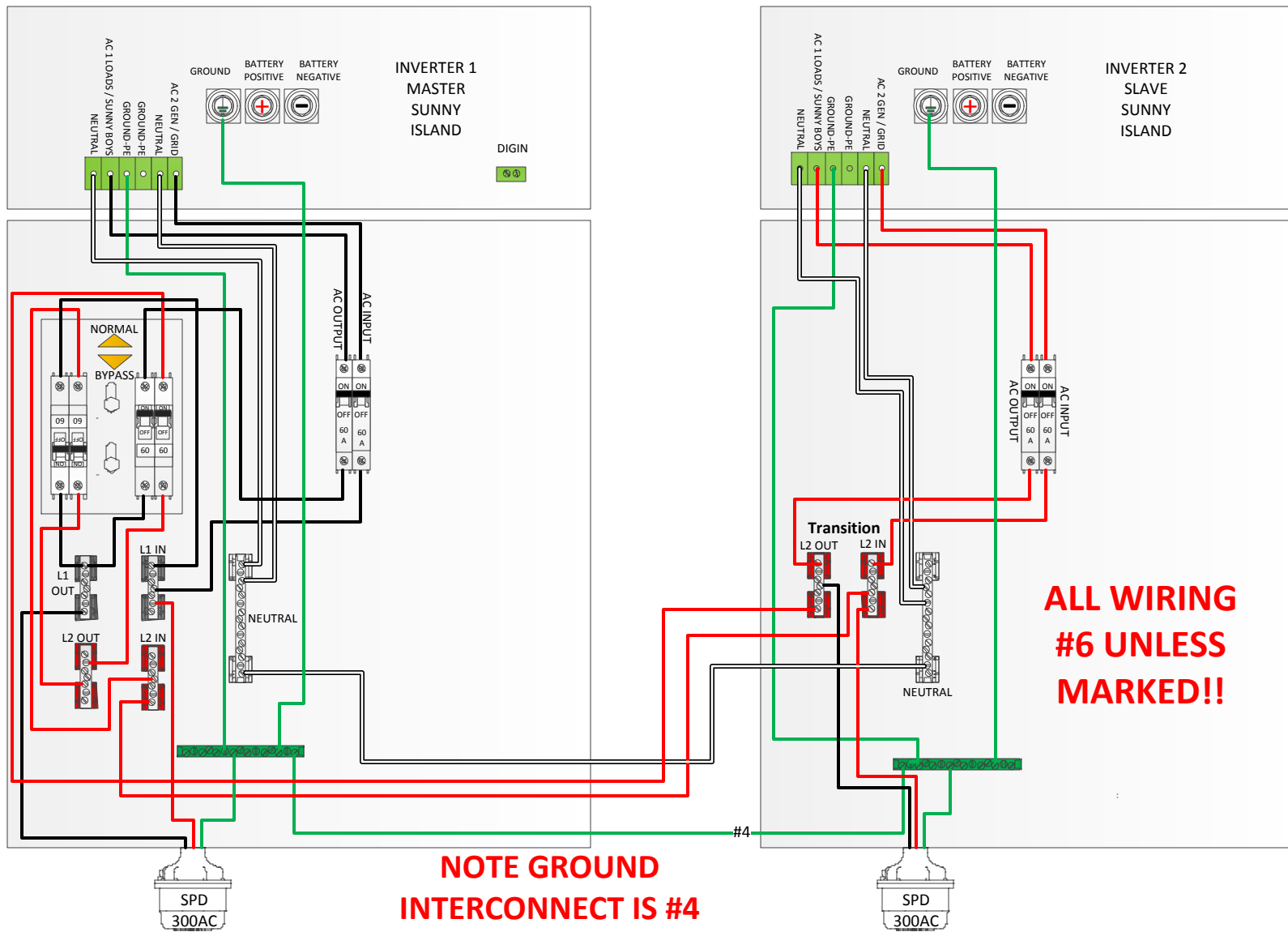

DC AND COMMUNICATION CABLES FACTORY INSTALLED BY MIDNITE SOLAR

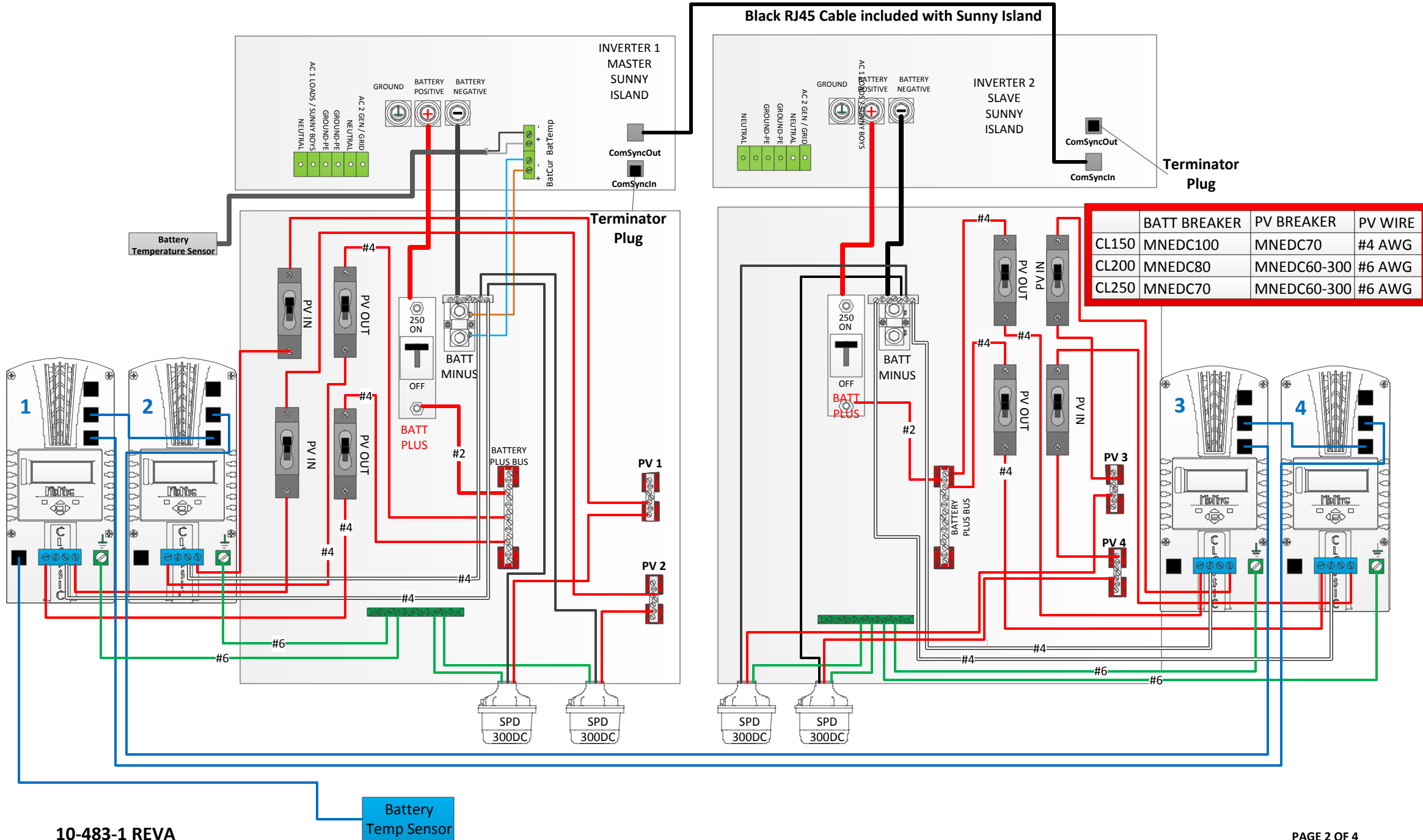

AC WIRING TO BE DONE BY CUSTOMER

System must be grounded per NEC specifications

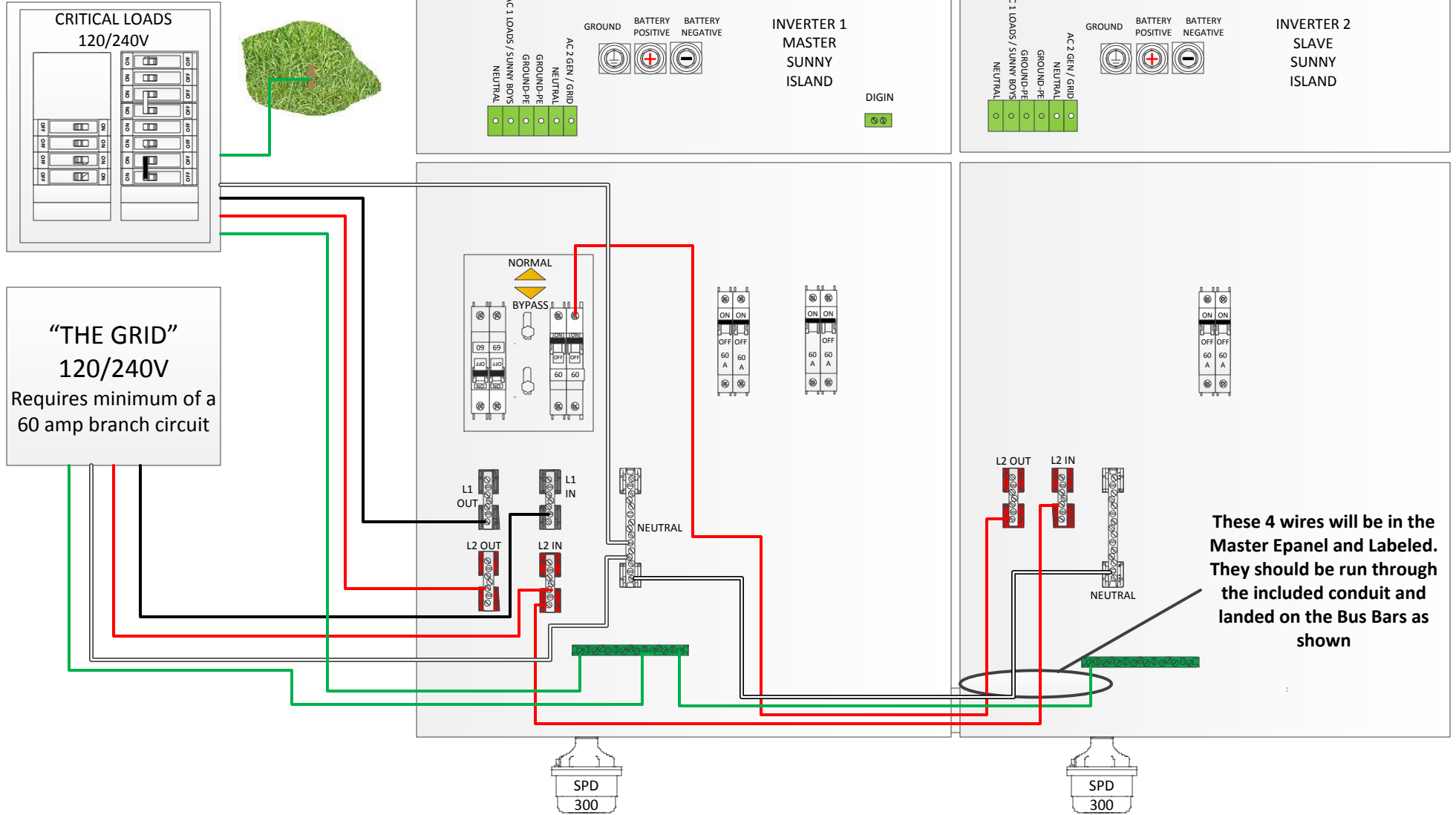

These 4 wires will be in the Master Epanel and Labeled. They should be run through the included conduit and landed on the Bus Bars as shown

CUSTOMER DC AND COMMUNICATIONS WIRING

