



MidNite Solar MNDISCOPSB Power Supply Board.

Accessory for use with most MidNite Disconnecting combiners as part of a Rapid System Shutdown.

The Midnite Solar BirdNest Power supply circuit board can be installed in most MidNite Solar Disconnecting Combiners. It is used in conjunction with one or more MNBH Disconnect switches and MidNite Solar disconnecting combiners to remotely shutdown the system in emergencies. The MNBN provides the power to trip the remote trip breaker from power stored in its capacitors from either the PV or external DC in inputs. The trip signal for the MNBNs is generated by the MNBH Disconnect Panel. Control signals are provided to the target devices via a ruggedized 600V CAT-5 cable, which connects all components in the system.

Electrical Ratings:

MAXIMUM INPUT VOLTAGE	600 VDC
RATED INPUT OPERATING VOLTAGE RANGE	60 - 600 VDC
RATED INPUT CURRENT	145 mA DC
OUTPUT VOLTAGE	48 VDC
RATED OUTPUT CURRENT	125 mA

The MNDISCOPSB is intended to be mounted in an enclosure protected from rain/snow and /splashing.

IMPORTANT SAFETY INSTRUCTIONS

SAVE THESE INSTRUCTIONS - These instructions contain important safety and operating instructions for The MNDISCOPSB (BirdNest) Power Supply Board that shall be followed during the installation and maintenance of the power system.

If you do not fully understand any of the concepts, terminology, or hazards outlined in these instructions, please refer installation to a qualified dealer, electrician or installer. These instructions are not meant to be a complete explanation of a renewable energy system. All installations must comply with national and local electrical codes. Professional installation is recommended.

GENERAL PRECAUTIONS:

WORKING WITH OR IN THE VICINITY OF A LEAD ACID BATTERY, SEALED OR VENTED IS DANGEROUS. VENTED BATTERIES GENERATE EXPLOSIVE GASES DURING NORMAL OPERATION. FOR THIS REASON, IT IS VERY IMPORTANT THAT BEFORE SERVICING EQUIPMENT IN THE VICINITY OF LEAD-ACID BATTERIES YOU REVIEW AND FOLLOW THESE INSTRUCTIONS CAREFULLY.

If service or repair should become necessary, contact MidNite Solar Inc. Improper servicing may result in a risk of shock, fire or explosion. To reduce these risks, disconnect all wiring before attempting any maintenance or cleaning. Turning off the inverter will not reduce these risks. Solar modules produce power when exposed to light. When it is not possible to disconnect the power coming from the Photovoltaics by an external means such as a combiner, cover the modules with an opaque material before servicing any connected equipment.

Do Not expose to rain or snow. Never attempt to charge a frozen battery. Do not smoke around batteries.

When it is necessary to remove a battery, make sure that the battery bank disconnect breaker is in the off position and that the PV breakers, grid breakers and any other sources of power to the inverter are in the off position. Then remove the negative terminal from the battery first.

To reduce risk of battery explosion follow these instructions and those published by the battery manufacturer as well as the manufacturer of any additional equipment used in the vicinity of the batteries.

Avoid producing sparks in the vicinity of the batteries when using vented batteries. Provide ventilation to clear the area of explosive gases. Sealed AGM and Gel batteries do not under normal conditions create explosive gases. Refer to the battery manufacturer's documentation. Be especially cautious when using metal tools. Dropping a metal tool onto batteries can short circuit them. The resulting spark can lead to personal injury or damage to the equipment. Provide ventilation to outdoors from the battery compartment when installing vented batteries such as golf cart T-105 batteries. The addition of a spill tray is also a good idea.

Clean all battery terminals. Very high currents are drawn from the batteries; even a small amount of electrical resistance can result in overheating, poor performance, premature failure or even fire.

Have plenty of fresh water and soap nearby in case battery acid contacts skin, clothing or eyes. Wear complete eye and clothing protection. Always avoid touching eyes while working near batteries. If battery acid or battery terminal corrosion contacts skin or clothing, wash immediately with soap and water. If acid enters the eyes, immediately flood with cool running water for at least 15 minutes and get medical attention immediately. Baking soda neutralizes battery acid electrolyte. Keep a supply near the batteries

Do not work alone. Someone should be in the range of your voice or close enough to come to your aid when you work with or near electrical equipment.

Remove rings, bracelets, necklaces, watches etc. when working with batteries, photovoltaic modules or other electrical equipment. Power from an illuminated photovoltaic array makes a very effective arc welder with dire consequences if one of the welded pieces is on your person.

To reduce the risk of injury, connect only deep cycle lead acid type rechargeable batteries. Other types of batteries may leak or burst, causing personal injury or damage.

Wiring methods used shall be in accordance with the Canadian Electrical Code, Part I.

Wiring must be done in accordance with the National Electrical Code Article 690 ANSI/NFPA 70. Use Class 1 wiring methods for field wiring connections to terminals of a Class 2 circuit. Use only 14-10 gauge AWM wire. Select the wire gauge used based on the protection provided by the circuit breakers/fuses. Overcurrent protection must be installed as part of the system installation. Refer to the wiring diagrams provided in this manual for breaker/fuse/GFDI sizes and model numbers.

Use of attachments or accessories not approved by MidNite Solar could result in damage or injury.

Before making any connections verify that the circuit breakers are in the off position including the inverter breaker. Double check all wiring before applying power.

Installing the MNDISCOPSB BirdNest Power Supply Power Supply PCB:

You will need:

3/16" Slotted screwdriver, #1 Phillips screwdriver, Wire strippers, ¼" nutdriver and a wire crimper to attach lugs.

First, verify contents of the MNDISCOPSB BirdNest Power Supply Kit.



Parts included with MNB Power Supply kit.

Qty	Description	MidNite Solar PN
1	PCB MNDiscoPSB	8-037-10
1	Formex Insulator	5-144-1
1	Wire 18 AWG Red	9-367-1
1	Wire 18 AWG White	9-390-1
1	Wire 18 AWG Black	9-421-2
1	Double Ferrule	6-166-1
2	Terminal 18-22 AWG	6-168-1
2	Screw 6-32	6-274-1
2	Standoff ½ Inch	6-154-1
1	Silicone Grease Packet	9-757-1
2	#6 Internal Tooth Washer	6-155-1
2	Circuit Board Support	6-148-1
2	Ring Terminal for 22-18AWG	9-427-1

Installing the MNDISCOPSB BirdNest Power Supply Power Supply PCB: Continued

Remove the top cover and deadfront.

Remove the deadfront:

Pry off the lid as shown using something like a screwdriver as a lever. The dead front will then come out easily.

Remove the 2 white standoffs in the top (Shown going in on step2)



Step 1: Place the Formex insulator as shown.



Step 2: Install metal standoffs (2) and Reinstall plastic PCB supports (2) .

Installing the MNDISCOPSB BirdNest Power Supply Power Supply PCB: Continued



Step 3A:
Set board in place as shown.



Step 3B:
Secure board with 6-32 screws (2).

Loosen wire bundle from switch
Trim wires to 5" and strip ¼"



Use copper and copper clad conductors only. Use 10 AWG to 30 AWG 90°C Wire

Step 4: Connect the two black wires to The left side of the terminal block marked "BK1" and "BK2". Connect the two red wires to the right side of the terminal block marked "S1" and "S2".
Torque to 7 IN-LBS (0.8 Nm)

Installing the MNDISCOPSB BirdNest Power Supply Power Supply PCB: Continued



Torque terminal block connections to 7 in-LBS (0.8 Nm).

Step 5: Strip one end on the red and white wires included in the kit $\frac{1}{4}$ " and connect them as shown with the red wire on the left side of the terminal block marked "PV+" and the white wire on the right side marked "PV-". Route the wires downward under the large switch.

Torque to 7 IN-LBS (0.8 Nm)



Step 5a: Strip the other end of the red and white wire about $\frac{1}{4}$ ". Install the red wire into the red ferrule and crimp, then install into the red terminal block. Put the white wire along with the black wire from the MNSPD into the ferrule and crimp. If no MNSPD is installed the white wire should be crimped into the other red ferrule and installed into the white terminal block.

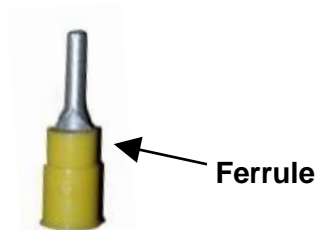

Installing the MNDISCOPSB BirdNest Power Supply Power Supply PCB: Continued

Step 6:

Installing the included MNSPD Surge protector with the MNDISCOPSB
First, select the mounting location for the MNSPD. There are several knockouts located on the sides and bottom that can be used for this. Remove the desired knockout, pull the MNSPD wires through and secure with the supplied nut.



MNSPD Shown installed in left side knockout.

Crimp one of the small red terminals on the red wire from the circuit board terminal block. Be sure to make a strong secure connection. The purpose of this terminal is to allow the 18 AWG wire to be held securely into the terminal strip.

The white wire from the circuit board terminal block may be crimped into the yellow terminal along with the black wire from the MNSPD or it may be crimped by itself into the second red terminal.

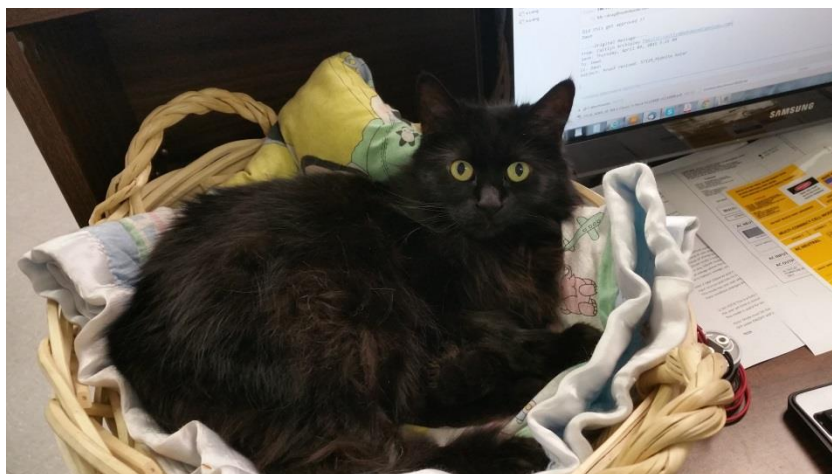

The company mascot "MidNite"

Installing the MNDISCOPSB BirdNest Power Supply Power Supply PCB: Continued

Step 7:

Verify your work and replace deadfront and top cover.

MAXIMUM INPUT VOLTAGE	600 VDC	10-219-1 (MNDISCOPSB)
RATED INPUT OPERATING VOLTAGE RANGE	60 - 600VDC	
RATED INPUT CURRENT	145 mA DC	
OUTPUT VOLTAGE	48 VDC	
RATED OUTPUT CURRENT	125 mA	

MNDISCOPSB ratings sticker goes here.

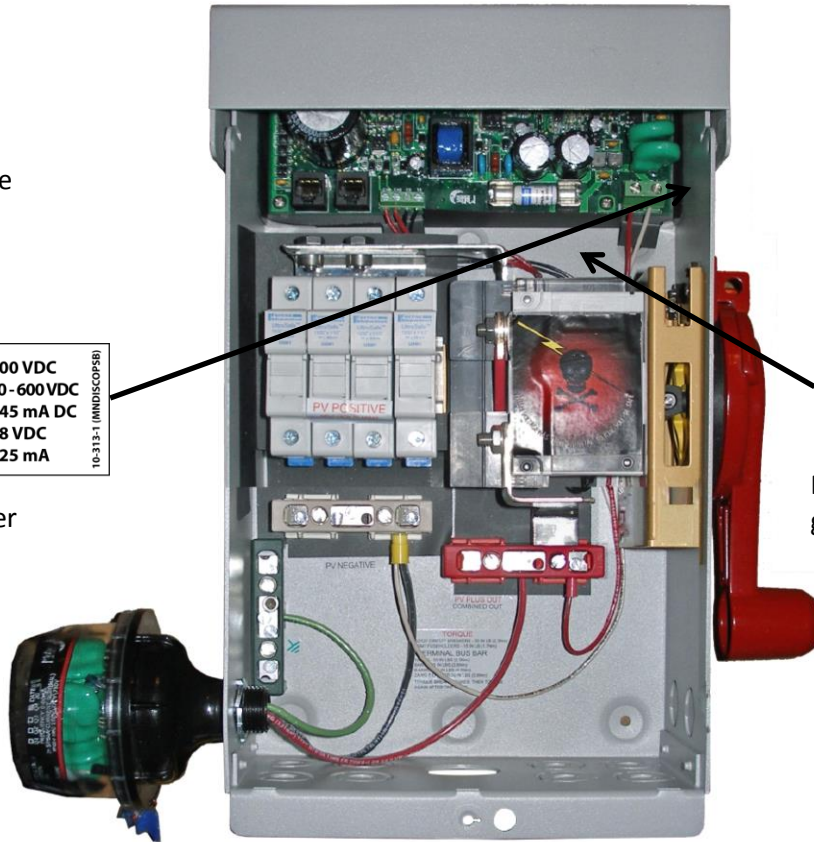

REPLACE ONLY WITH SAME TYPE AND RATINGS OF FUSE.
LITTELFUSE SPF4
4 AMPS 1000 VDC

FUSE ratings sticker goes here.

MNPVHV4 TYPE 3R Shown wired with MNDiscoPSB power supply board and MNSPD surge protector.

Important!

A small packet of silicone gel is included with the MNDISCOPSB. This is used to protect the connectors on the CAT-5 cable. Only use a gel intended for protecting electrical connections of this type such as the gel that ships with the BirdHouse. Other types may interfere with the connections and may damage the board or and/or cable.

To Open:
Tear here.



Tear off the tip of the packet at the notch and squeeze out some gel. You will want to get a good amount of gel in the connection. You can put some inside the connector on the board and some on the connector at the end of the cable as well. It does not need to be oozing out, just so that the connections are thoroughly coated. Without the protective gel the connectors can corrode leading to failure of the system.



Apply silicone gel to these connectors

Connecting to the Rapid Shutdown System

(Refer to the MNBH Installation manual 10-192-1 for additional information.)

Remove power from combiner, etc.

Remove deadfront

NOTE: The CAT-5 connectors on the MNBH (Sold Separately) power board are labeled US (Up Stream) and BH/DS (Birdhouse / Down Stream). Upstream is going farther away from the control point, which is the Birdhouse. Down Stream is going toward the Birdhouse.

The main CAT-5 cable goes from the first combiner to the control end of the Rapid Shutdown System. Typically this device will be the Primary Birdhouse, but it may go to an MNBDM then to the Birdhouse, depending on the design of the system. Apply silicone gel and connect the combiner end this cable to the BH/DS jack (rightmost of the two RJ-45 connectors.) Apply silicone gel and connect the other end to the Birdhouse or other device.

If there is a second combiner there will be a CAT-5 cable run needed between the first and second combiners. This cable must be connected from the US (Up Stream) jack BH/DS jack on the first combiner to the BH/DS jack on the second combiner.

If there is a third combiner, the CAT-5 cable between the second and third is wired from the BH/DS jack on the third combiner to the US jack on the second. The US jack on the last connector will always be unused. NEVER create a loop in the control cable.

Replace deadfront. Restore power and test the system.

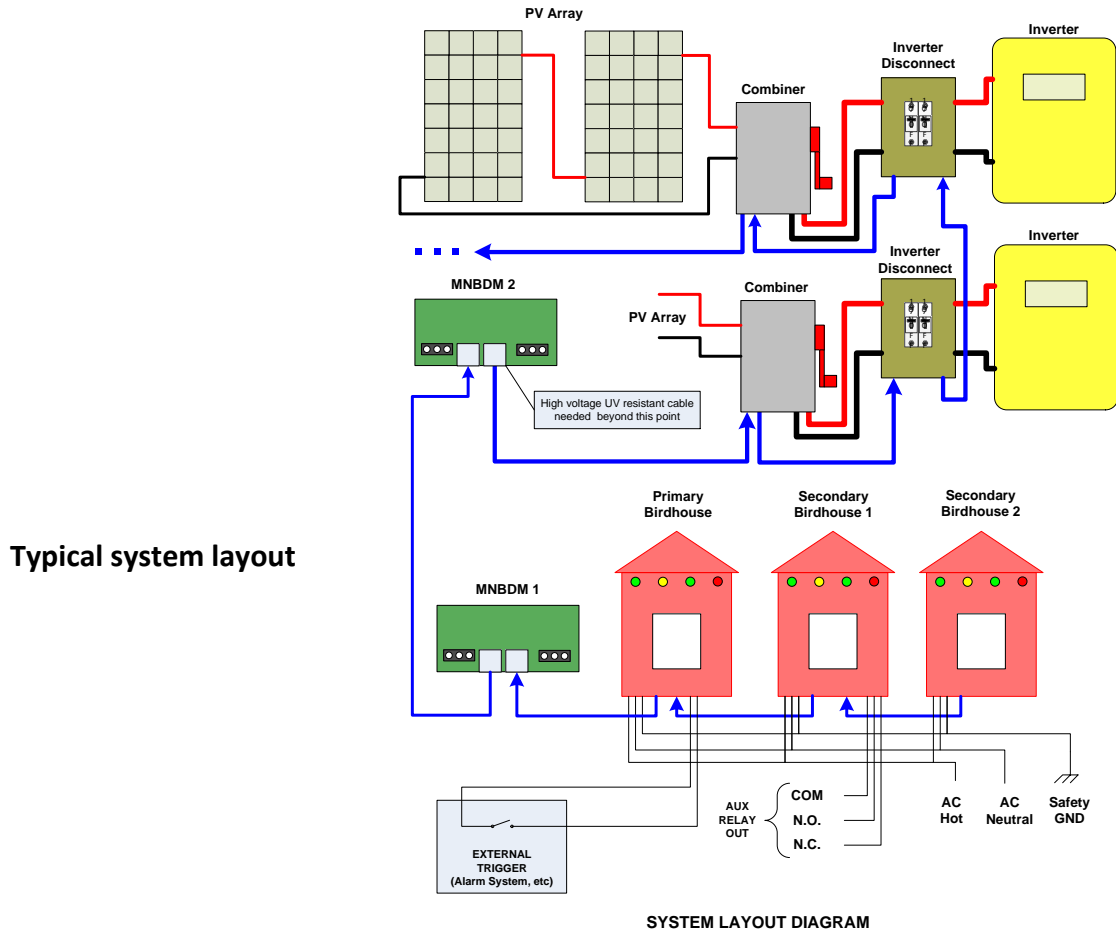

Typical system layout



MidNite Solar 17722 67th Ave NE Arlington, Wa USA 98223
 P: 360.403.7207 F: 360.691.6862 www.midnitesolar.com